

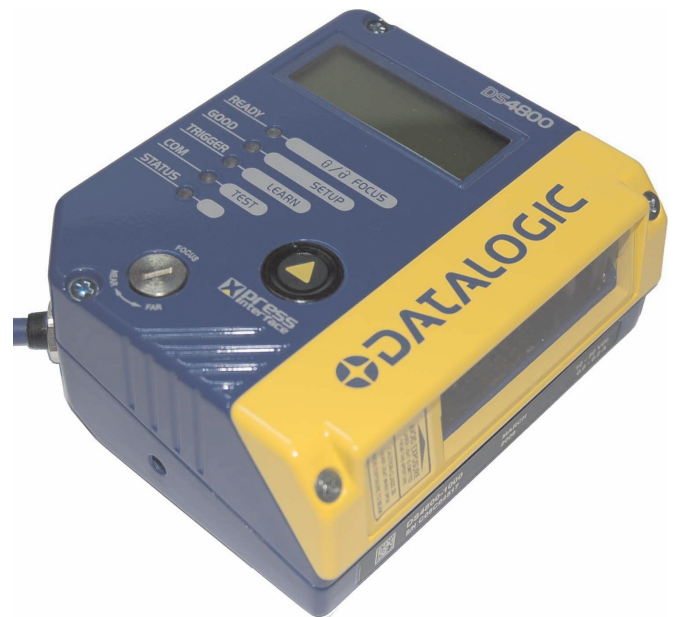

DS4800



Reference Manual



Datalogic Automation Srl
Via S. Vitalino, 13
40012 - Lippo di Calderara di Reno
Bologna - Italy

DS4800 Reference Manual

Ed.: 03/2010

© 2008 – 2010 Datalogic Automation S.r.l. ♦ ALL RIGHTS RESERVED. ♦ Protected to the fullest extent under U.S. and international laws. Copying, or altering of this document is prohibited without express written consent from Datalogic Automation S.r.l.

Datalogic and the Datalogic logo are registered trademarks of Datalogic S.p.A. in many countries, including the U.S.A. and the E.U.

ID-NET, Genius and X-PRESS are trademarks of Datalogic Automation S.r.l. All other brand and product names mentioned herein are for identification purposes only and may be trademarks or registered trademarks of their respective owners.

Datalogic shall not be liable for technical or editorial errors or omissions contained herein, nor for incidental or consequential damages resulting from the use of this material.

23/03/10

CONTENTS

REFERENCES	v
Conventions	v
Reference Documentation	v
Services and Support	v
Patents.....	v
SAFETY AND COMPLIANCE NOTICES	vi
Laser Safety.....	vi
FCC Compliance	vii
Power Supply.....	vii
CE Compliance.....	vii
Handling.....	viii
GENERAL VIEW	x
1 RAPID CONFIGURATION	1
Step 1 – Connect the System	1
Step 2 – Mount and Position the Scanner	4
Step 3 – Focus the Scanner	6
Step 4 – X-PRESS™ Configuration.....	7
Step 5 – Install Genius™ Configuration Program.....	11
Step 6 – Test Mode	16
Advanced Scanner Configuration	17
2 INTRODUCTION	18
2.1 Product Description	18
2.1.1 Indicators	19
2.2 ID-NET™	19
2.2.1 How To Setup/Configure the Scanner Network.....	21
2.3 X-PRESS™ Human Machine Interface	22
2.3.1 Diagnostic Indication.....	22
2.3.2 X-PRESS™ Functions.....	23
2.4 Display	25
2.4.1 Display Messages.....	26
2.5 Oscillating Mirror Models	29
2.6 Subzero Temperature Models	30
2.7 Model Description	31
2.8 Accessories	31
3 INSTALLATION	33
3.1 Package Contents	33
3.2 Mechanical Installation	34
3.2.1 Mounting DS4800	37
3.3 Positioning	40
4 CBX ELECTRICAL CONNECTIONS	42
4.1 Power Supply.....	43
4.2 Main Serial Interface.....	43
4.2.1 RS232 Interface.....	44
4.2.2 RS485 Full-Duplex Interface.....	45
4.2.3 RS485 Half-Duplex Interface	46
4.3 ID-NET™ Interface	48

4.3.1	ID-NET™ Cables	48
4.3.2	ID-NET™ Response Time	49
4.3.3	ID-NET™ Network Termination	53
4.4	Auxiliary RS232 Interface	53
4.5	Inputs	54
4.5.1	Code Verifier	57
4.6	Outputs	57
4.7	User Interface - Host.....	59
5	25-PIN CABLE ELECTRICAL CONNECTIONS.....	60
5.1	Power Supply.....	61
5.2	Main Serial Interface.....	61
5.2.1	RS232 Interface.....	62
5.2.2	RS485 Full-Duplex Interface.....	63
5.2.3	RS485 Half-Duplex Interface	64
5.3	ID-NET™ Interface	66
5.3.1	ID-NET™ Cables.....	66
5.3.2	ID-NET™ Response Time	67
5.3.3	ID-NET™ Network Termination.....	71
5.4	Auxiliary RS232 Interface	71
5.5	Inputs.....	72
5.5.1	Code Verifier.....	75
5.6	Outputs	75
5.7	User Interface - Host.....	76
6	TYPICAL LAYOUTS	77
6.1	Point-to-Point.....	77
6.2	Pass-Through	79
6.3	ID-NET™	81
6.4	RS232 Master/Slave.....	86
6.5	Multiplexer Layout.....	87
7	READING FEATURES.....	88
7.1	Advanced Code Reconstruction (ACR™ 4).....	88
7.1.1	Tilt Angle for Advanced Code Reconstruction	89
7.1.2	Advanced Code Reconstruction Reading Conditions.....	90
7.2	Linear Code Reading.....	92
7.2.1	Step-Ladder Mode	92
7.2.2	Picket-Fence Mode.....	93
7.3	Performance	94
7.4	Reading Diagrams	95
7.4.1	X0XX Standard Models	95
7.4.2	X1XX Oscillating Mirror Models	98
7.4.3	XXX5 Subzero Models.....	101
8	MAINTENANCE	104
8.1	Cleaning.....	104
9	TROUBLESHOOTING	105
9.1	General Guidelines.....	105
10	TECHNICAL FEATURES.....	108
	GLOSSARY.....	110
	INDEX.....	113

REFERENCES

CONVENTIONS

This manual uses the following conventions:

“User” or “Operator” refers to anyone using a DS4800.

“Device” refers to the DS4800.

“You” refers to the System Administrator or Technical Support person using this manual to install, mount, operate, maintain or troubleshoot a DS4800.

REFERENCE DOCUMENTATION

The documentation related to the DS4800 management is listed below:

- CBX100 Installation Manual
- CBX500 Installation Manual
- CBX Accessory Manuals
- Genius™ Help On Line

SERVICES AND SUPPORT

Datalogic provides several services as well as technical support through its website. Log on to www.automation.datalogic.com and click on the [links](#) indicated for further information:

- **PRODUCTS**

Search through the links to arrive at your product page which describes specific Info, Features, Applications, Models, Accessories, and Downloads including the [Genius™](#) utility program, which allows device configuration using a PC. It provides RS232 and Ethernet interface configuration.

- **SERVICE**

- **Overview** - Warranty Extensions and Maintenance Agreements
- **Sales Network**- Listing of Subsidiaries, Repair Centers, Partners
- **Helpdesk**
- **Material Return Authorization**

PATENTS

This product is covered by one or more of the following patents:

U.S. patents: 5,992,740; 6,394,352 B1; 6,742,710 B2; 6,688,524 B1

European patents: 789,315 B1; 959,426 B9; 1,096,416 B1.

Japanese patents: 4,376,353.

Additional patents pending.

SAFETY AND COMPLIANCE NOTICES

LASER SAFETY

The following information is provided to comply with the rules imposed by international authorities and refers to the correct use of the DS4800 scanner.

Standard Regulations

This scanner utilizes a low-power laser diode. Although staring directly at the laser beam momentarily causes no known biological damage, avoid staring at the beam as one would with any very strong light source, such as the sun. Avoid that the laser beam hits the eye of an observer, even through reflective surfaces such as mirrors, etc.

This product conforms to the applicable requirements of both EN 60825-1 and CDRH 21 CFR 1040 at the date of manufacture. The scanner is classified as a Class 2 laser product according to EN 60825-1 regulations and as a Class II laser product according to CDRH regulations.

There is a safety device, which allows the laser to be switched on only if the motor is rotating above the threshold for its correct scanning speed.

The laser beam can be switched off through a software command (see also the Genius™ Help On Line).

	<i>Use of controls or adjustments or performance of procedures other than those specified herein may result in exposure to hazardous visible laser light.</i>
WARNING	

The laser light is visible to the human eye and is emitted from the window on the front of the scanner ([Figure A](#), 5).

Warning labels indicating exposure to laser light and the device classification are applied onto the body of the scanner.

Disconnect the power supply when opening the device during maintenance or installation to avoid exposure to hazardous laser light.

The laser diode used in this device is classified as a class 3B laser product according to EN 60825-1 regulations and as a Class IIIb laser product according to CDRH regulations.

Any violation of the optic parts in particular can cause radiation up to the maximum level of the laser diode (40 mW at 630 to 680 nm).

AVOID EXPOSURE LASER LIGHT IS EMITTED FROM THIS APERTURE
CAUTION-CLASS 3B LASER LIGHT WHEN OPEN AVOID EXPOSURE TO BEAM

 C US 218441	This product conforms to the applicable requirements of 21CFR1040 at the date of manufacture	
		EN2468
	LASER LIGHT DO NOT STARE INTO BEAM CLASS 2 LASER PRODUCT MAX. OUTPUT RADIATION 1 mW EMITTED WAVE LENGTH 630-680 nm TO EN 60825-1:1993; A1 2001	
U.S. pat. 5,992,740; 6,394,352B1; 6,742,710B2; 6,688,524B1. EP pat. 789,315B1; 959,426B9 DATALOGIC AUTOMATION S.r.l. Via S. Vitalino, 13 - 40012 Calderara di Reno MADE IN ITALY-www.datalogic.com		

Warning and Device Class Labels

FCC COMPLIANCE

Modifications or changes to this equipment without the expressed written approval of Datalogic could void the authority to use the equipment.

This device complies with PART 15 of the FCC Rules. Operation is subject to the following two conditions: (1) This device may not cause harmful interference, and (2) this device must accept any interference received, including interference which may cause undesired operation.

This equipment has been tested and found to comply with the limits for a Class A digital device, pursuant to part 15 of the FCC Rules. These limits are designed to provide reasonable protection against harmful interference when the equipment is operated in a commercial environment. This equipment generates, uses, and can radiate radio frequency energy and, if not installed and used in accordance with the instruction manual, may cause harmful interference to radio communications. Operation of this equipment in a residential area is likely to cause harmful interference in which case the user will be required to correct the interference at his own expense.

POWER SUPPLY

This product is intended to be installed by Qualified Personnel only.

This accessory device is intended to be supplied by a UL Listed or CSA Certified Power Unit with «Class 2» or LPS power source, which supplies power directly to the scanner via the 25-pin connector.

CE COMPLIANCE

Warning:

This is a Class A product. In a domestic environment this product may cause radio interference in which case the user may be required to take adequate measures.

HANDLING

The DS4800 is designed to be used in an industrial environment and is built to withstand vibration and shock when correctly installed, however it is also a precision product and therefore before and during installation it must be handled correctly to avoid damage.

- avoid that the scanners hit one another causing damage. They should be handled separately.

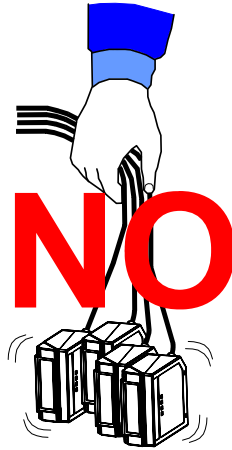

- avoid that the scanners are dropped (exceeding shock limits).



- do not fine tune the positioning by striking the scanner or bracket.

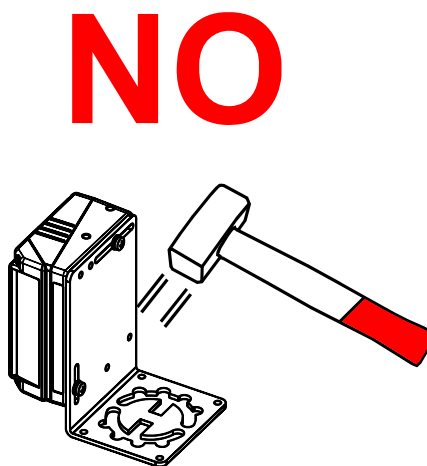

- do not weld the scanner into position which can cause electrostatic, heat or output window damage.

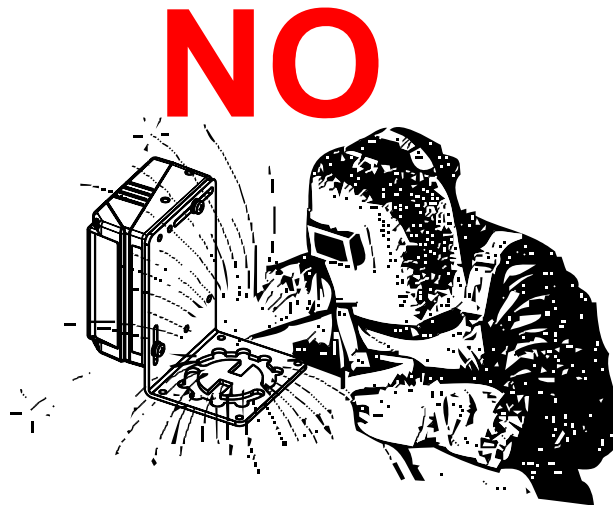

- do not spray paint near the scanner which can cause output window damage.



GENERAL VIEW

DS4800-X0XX



Figure A

- | | |
|--------------------|----------------------------|
| ① "POWER ON" LED | ④ Display |
| ② Focus Adjustment | ⑤ Laser Beam Output Window |
| ③ Indicator LEDs | ⑥ Push Button |

DS4800-X1XX

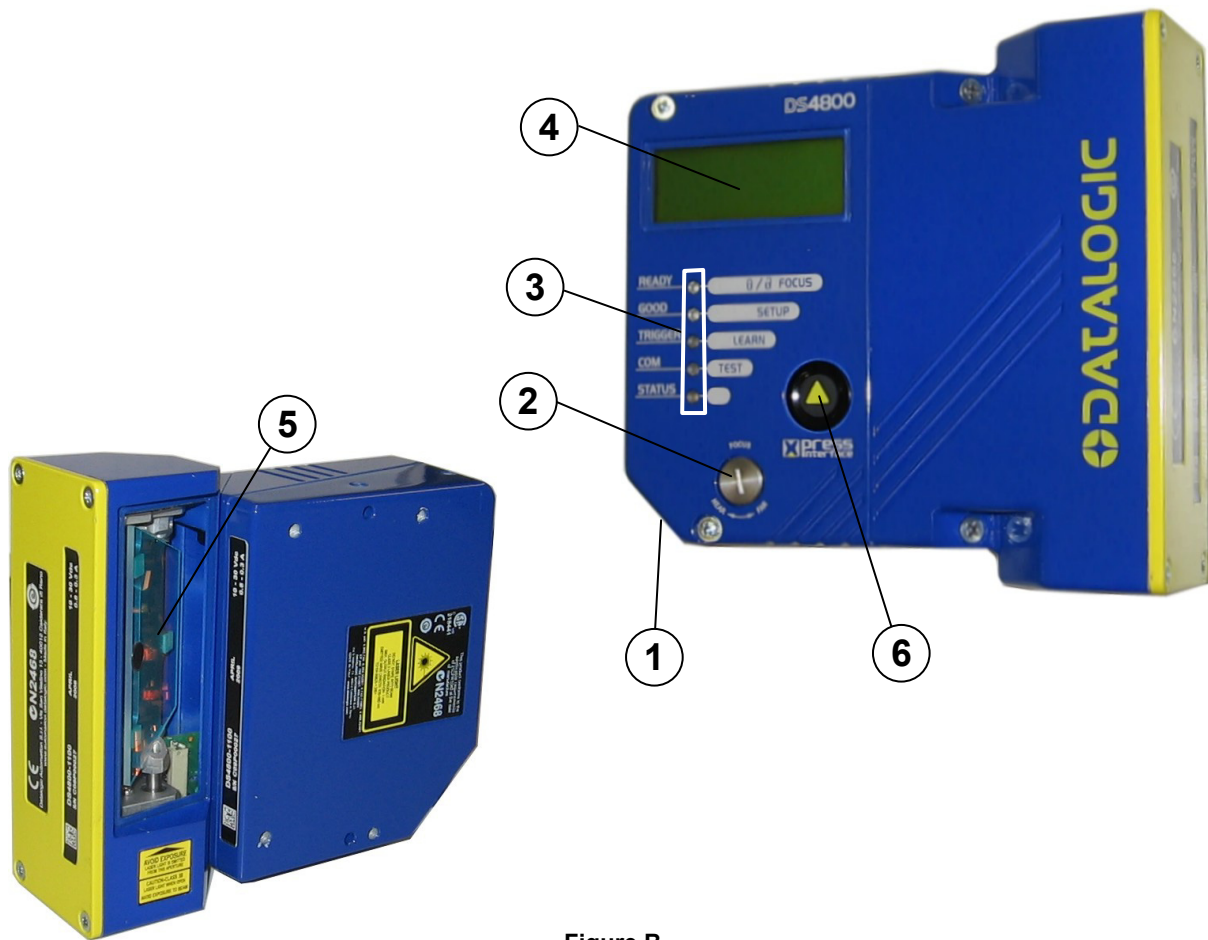



Figure B

- | | |
|--------------------|----------------------------|
| ① "POWER ON" LED | ④ Display |
| ② Focus Adjustment | ⑤ Laser Beam Output Window |
| ③ Indicator LEDs | ⑥ Push Button |

1 RAPID CONFIGURATION



NOTE

This chapter illustrates a Stand Alone application. For other types of installations, such as ID-NET™, Fieldbus, Pass-Through, Multiplexer Layout, etc., refer to chapters 4, 5 and 6. For complete scanner configuration using the Genius™ configuration program, refer to the Context-Sensitive Help On-Line.

STEP 1 – CONNECT THE SYSTEM

To connect the system in a Stand Alone configuration, you need the hardware indicated in Figure 1.

In this layout the data is transmitted to the Host on the main serial interface.

In Local Echo communication mode, the RS232 auxiliary interface can be used to transmit data independently from the main interface selection.

When On-Line Operating mode is used, the scanner is activated by an External Trigger (photoelectric sensor) when the object enters its reading zone.

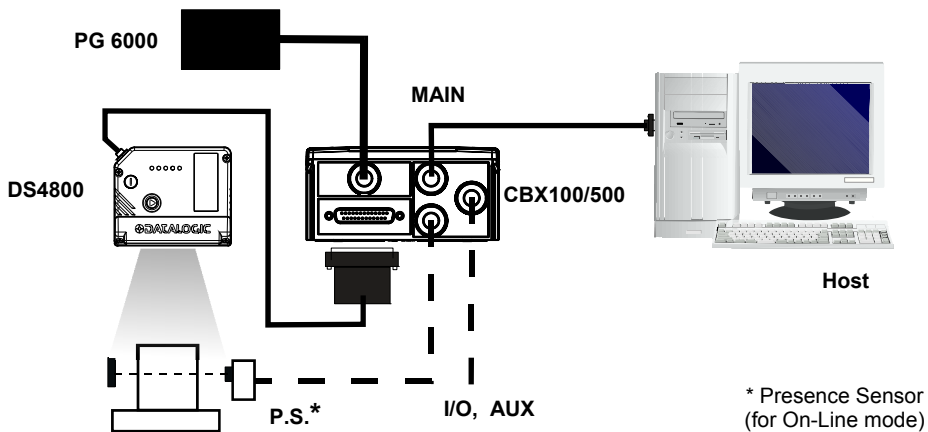

Figure 1 – DS4800 in Stand Alone Layout

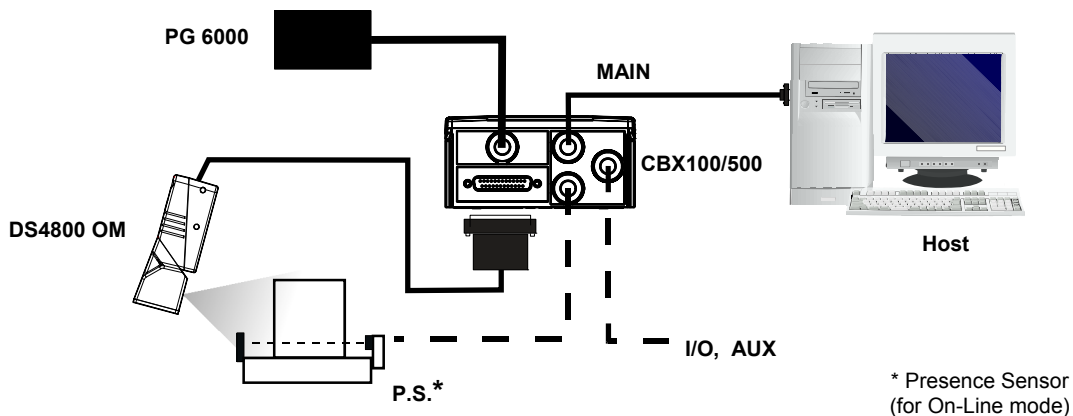

Figure 2 – DS4800 OM in Stand Alone Layout

CBX100/500 Pinout for DS4800

The table below gives the pinout of the CBX100/500 terminal block connectors. Use this pinout when the DS4800 reader is connected by means of the CBX100/500:

CBX100/500 Terminal Block Connectors			
Input Power		Outputs	
Vdc	Power Supply Input Voltage +	+V	Power Source - Outputs
GND	Power Supply Input Voltage -	-V	Power Reference - Outputs
Earth	Protection Earth Ground	O1+	Output 1 +
		O1-	Output 1 -
Inputs		O2+	Output 2 +
+V	Power Source – External Trigger	O2-	Output 2 -
I1A	External Trigger A (polarity insensitive)	Auxiliary Interface	
I1B	External Trigger B (polarity insensitive)	TX	Auxiliary Interface TX
-V	Power Reference – External Trigger	RX	Auxiliary Interface RX
+V	Power Source – Inputs	SGND	Auxiliary Interface Reference
I2A	Input 2 A (polarity insensitive)	ID-NET™	
I2B	Input 2 B (polarity insensitive)	REF	Network Reference
-V	Power Reference – Inputs	ID+	ID-NET™ network +
Shield		ID-	ID-NET™ network -
Shield	Network Cable Shield		
Main Interface			
	RS232	RS485 Full-Duplex	RS485 Half-Duplex
	TX	TX+	RTX+
	RTS	TX-	RTX-
	RX	*RX+	
	CTS	*RX-	
	SGND	SGND	SGND

* Do not leave floating, see par. 4.2.2 for connection details.



CAUTION

Do not connect GND, SGND and REF to different (external) ground references. GND, SGND and REF are internally connected through filtering circuitry which can be permanently damaged if subjected to voltage drops over 0.8 Vdc.

25-pin Connector Pinout for DS4800

The table below gives the pinout of the 25-pin male D-sub connector for connection to the power supply and input/output signals. Use this pinout when the DS4800 reader is connected by means of the 25-pin connector:

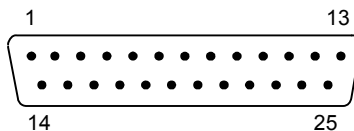

Figure 3 - 25-pin Male D-sub Connector

25-pin D-sub male connector pinout				
Pin	Name	Function		
13, 9	Vdc	Power supply input voltage +		
25, 7	GND	Power supply input voltage -		
1	CHASSIS	Cable shield connected to chassis		
18	I1A	External Trigger A (polarity insensitive)		
19	I1B	External Trigger B (polarity insensitive)		
6	I2A	Input 2 A (polarity insensitive)		
10	I2B	Input 2 B (polarity insensitive)		
8	O1+	Output 1 +		
22	O1-	Output 1 -		
11	O2+	Output 2 +		
12	O2-	Output 2 -		
20	RX	Auxiliary RS232 RX		
21	TX	Auxiliary RS232 TX		
23	ID+	ID-NET™ network +		
24	ID-	ID-NET™ network -		
14, 15, 16, 17	NC	Not Connected		
Pin	Name	RS232	RS485 Full-Duplex	RS485 Half-Duplex
2	MAIN INTERFACE (SW SELECTABLE)	TX	TX+	RTX+
3		RX	*RX+	
4		RTS	TX-	RTX-
5		CTS	*RX-	

* Do not leave floating, see par. 5.2.2 for connection details.

STEP 2 – MOUNT AND POSITION THE SCANNER

DS4800 Standard and Subzero Models

- To mount the DS4800, use the mounting bracket to obtain the most suitable position for the reader as shown in the figures below.

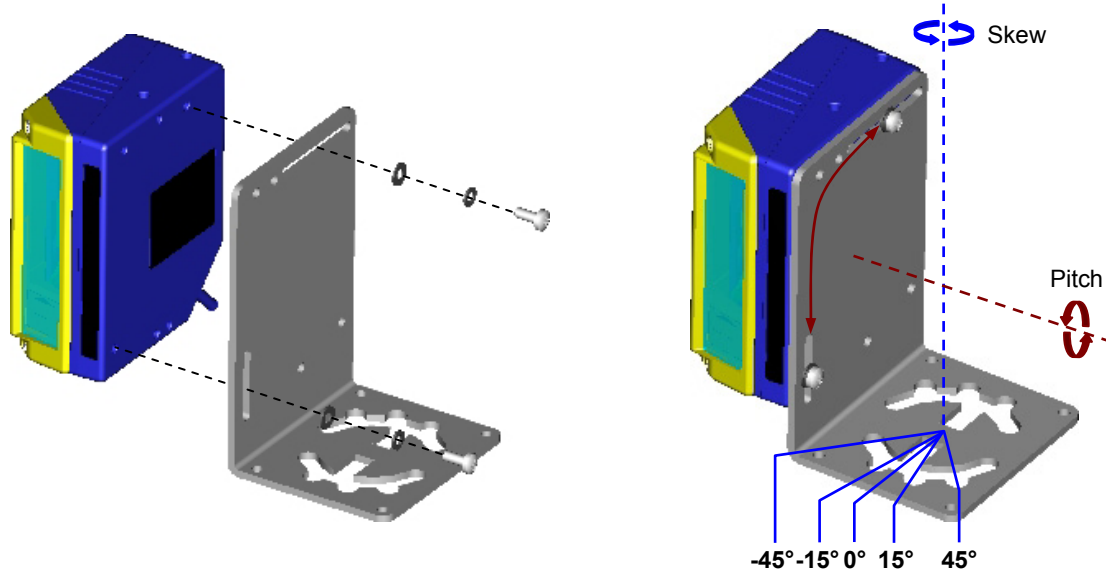

Figure 4 - Positioning with Mounting Bracket

- When mounting the DS4800 take into consideration these three ideal label position angles: **Skew 15° to 30°, Tilt 0° and Pitch 0°.**

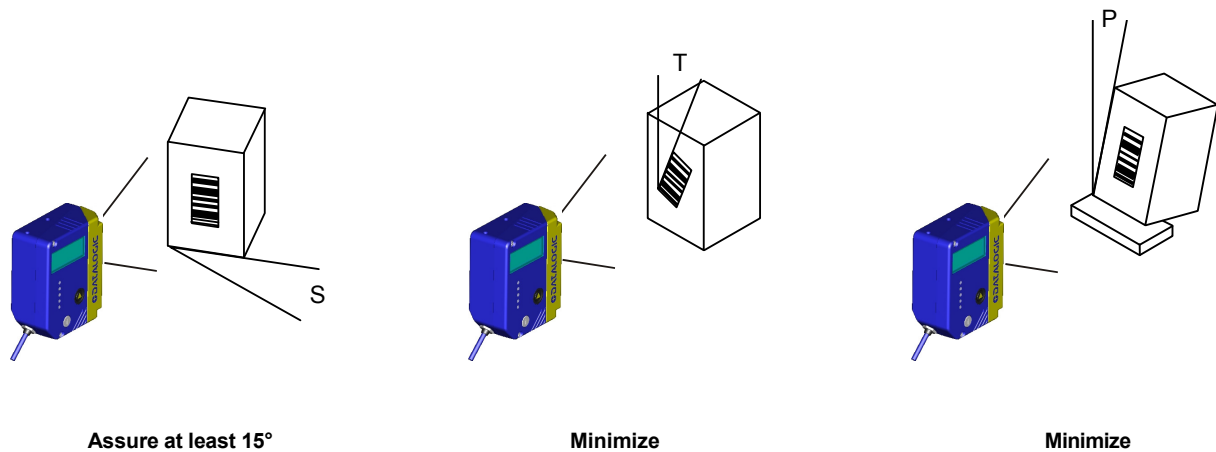

Figure 5 –Skew, Tilt and Pitch Angles

- Refer to the Reading Diagrams in par. 7.4 to decide the distance your scanner should be positioned at.

DS4800 OM Models

1. To mount the DS4800 OM, use the mounting bracket to obtain the most suitable position for the reader as shown in the figures below.

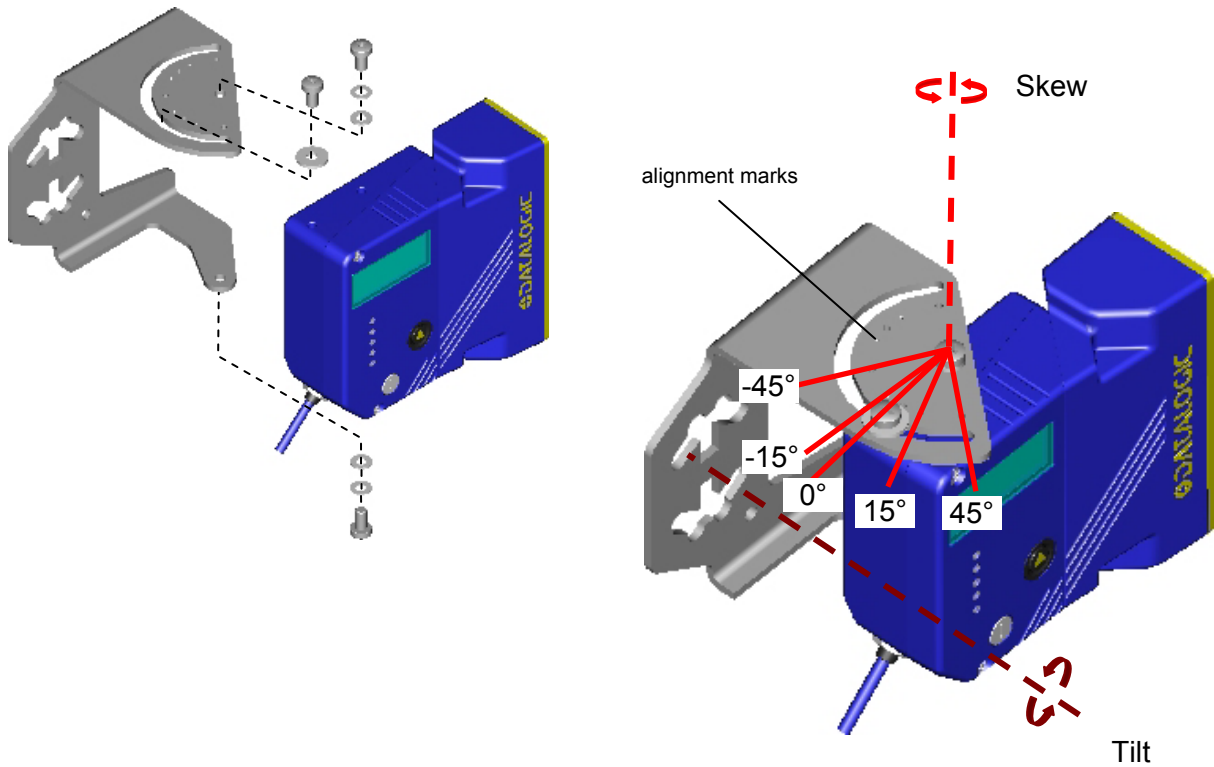

Figure 6 - Positioning with Mounting Bracket

2. When mounting the DS4800 OM take into consideration these three ideal label position angles: **Skew 15° to 30°**, **Tilt 0°** and **Pitch 0°**. The Skew angle refers to the most inclined or external raster line, so that all other raster lines assure **more** than 15° Skew.

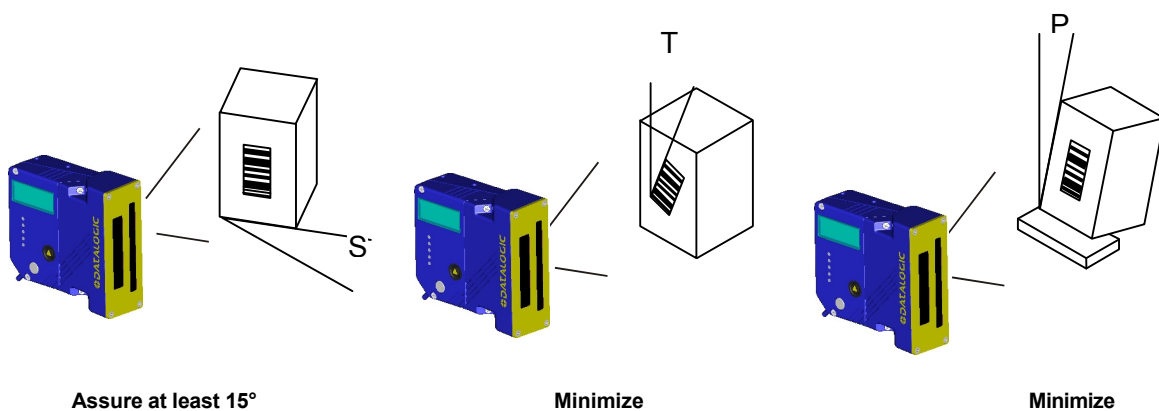

Figure 7 -Skew, Tilt and Pitch Angles

3. Refer to the Reading Diagrams in par. 7.4.2 to decide the distance your scanner should be positioned at.

STEP 3 – FOCUS THE SCANNER

The reading distance depends on the focus distance of the scanner and should be set according to the application requirements. The Focus Position is set directly through the focus adjustment screw on the front panel of the scanner. This screw moves the internal lens of the scanner to change the focal length of the scanner. The setting is continuous but should not be set beyond the limits "Too Far" or "Too Near" which appear on the display at the extremes of the focus range. Although the scanner reads across the entire focus range, there are three guaranteed positions which correspond to the reading diagrams in par. 7.4.

1. Power up the scanner. For Subzero models, At -35 °C, a 20-minute warm-up period is required before the scanner is ready to read barcodes, the Ready LED blinks. Wait for the power up sequence to finish. By default the scanner focus is in the Unlocked position. The alternating message on the display shows the mechanical Focus Position.
2. Using a screwdriver turn the focus adjustment screw in the desired direction, clockwise (focus nearer to the scanner) or counterclockwise (focus farther from the scanner). The focus position in centimeters and inches is shown on the scanner display.



NOTE The value of the Focus Position must be stored in memory. If the mechanical position changes by more than the allowed tolerance of the value in memory, an alarm will be sent. See the Focus Lock function in step 4, X-PRESS™ Configuration.

As an additional visual aid during focusing, the indicator LEDs show the relative focus position as follows:

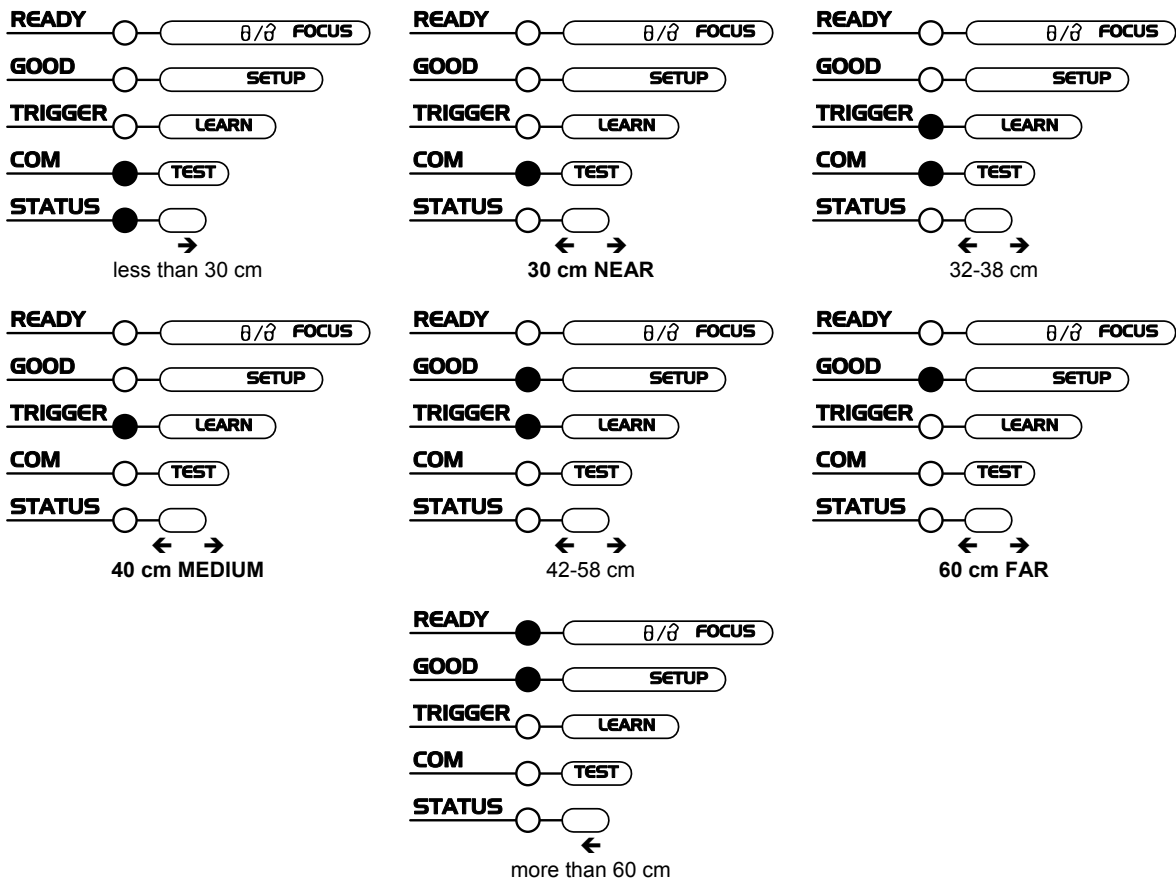

STEP 4 – X-PRESS™ CONFIGURATION

X-PRESS™ is the intuitive Human Machine Interface designed to improve ease of installation and maintenance.

Status and diagnostic information are clearly presented by means of the five colored LEDs, whereas the single push button gives immediate access to the following relevant functions:

- *AutoSetup* to self-optimize and auto-configure reading performance in demanding applications
- *AutoLearn* to self-detect and auto-configure for reading unknown barcodes (by type and length)
- *Focus Lock* to memorize the mechanical focus position
- *Test Mode* with bar graph visualization to check static reading performance



The colors and meaning of the five LEDs are illustrated in the following table:

LED	Color	Description
READY	Green	This LED indicates the device is ready to operate. For Subzero models this LED blinks during the warm-up phase.
GOOD	Green	This LED confirms successful reading.
TRIGGER	Yellow	This LED indicates the status of the reading phase. *
COM	Yellow	This LED indicates active communication on main serial port. **
STATUS	Red	This LED indicates a NO READ result.

* In On-Line mode the TRIGGER LED corresponds to the active reading phase signaled by the Presence Sensor. In Automatic and Continuous modes the TRIGGER LED is always on indicating that the reader is ready to read a code.

** When connected to a Fieldbus network through the CBX500, the COM LED is always active, even in the absence of data transmission, because of polling activity on the Fieldbus network.

During the reader startup (reset or restart phase), all the LEDs blink for one second.

On the back of the reader near the cable, the “POWER ON” LED indicates the laser scanner is correctly powered.

 NOTE	<p>When entering the X-PRESS™ interface on the DS4800-X1XX the Oscillating Mirror remains in the default fixed position (0°) in order to make barcode reading easier while performing the X-PRESS™ functions.</p>
--	--

Auto Learn

If you are configuring your scanner using X-PRESS™, you must start with the *Auto Learn* procedure.

1. Enter the *Auto Learn* function by holding the X-PRESS™ push button pressed until the LEARN LED is on.
2. Release the button to enter the *Auto Learn* function.
Once entered, the reader starts a procedure to automatically detect and recognize barcodes (by type and length), which are presented to it (*). The laser turns on and the LEARN LED blinks to indicate the ongoing process.

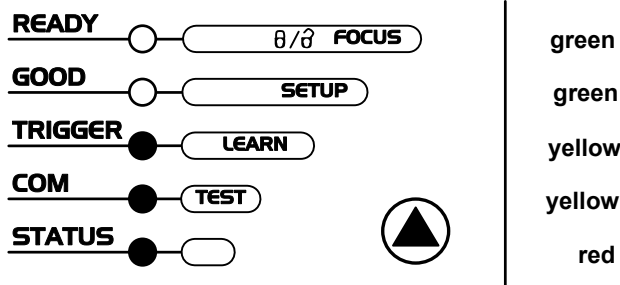

Figure 8 – X-PRESS™ Interface: Auto Learn Function

The procedure is as follows:

- A) **place** the desired barcode on the scanline.
- B) **wait** until the LEARN LED stays steady on (indicating the reader has detected the barcode).
- C) **repeat**, if needed, the above two steps to program up to 10 different barcodes (the LEARN LED returns to the blinking state for the next code). If more than one barcode is detected in the scan line, the Multi Label mode is enabled (refer to the “2K/4K Family Software Configuration Parameter Guide” Help file).

3. **Exit** the process by pressing the X-PRESS™ push button once. The scanner will restart at the end of the process, and then the detected barcodes are automatically configured in scanner memory.



NOTE

If the barcode cannot be read because of low contrast or excessive ambient light, you can perform the AutoSetup function to optimize the optical parameters. Then you can perform AutoLearn to recognize the barcode symbology.



NOTE

On exit from Autolearn, the following parameters are forced: Code Combination = Single Label, Reading Mode = Linear. If necessary, these parameters can be changed through Genius™.

* In case of Programming Barcodes, refer to the “Setup Procedure Using Programming Barcodes” document in the product CD.

Auto Setup (Optional)

At the end of the *Auto Learn* procedure, you have the possibility to follow the *Auto Setup* procedure to set up the reading parameters.

1. Enter the *Auto Setup* function by holding the X-PRESS™ push button pressed until the SETUP LED is on.
2. Release the button to enter the *Auto Setup* function.
3. Once entered, if a barcode label is positioned in front of the scanline, the scanner automatically performs the optimal setup of the reading parameters for that specific barcode.

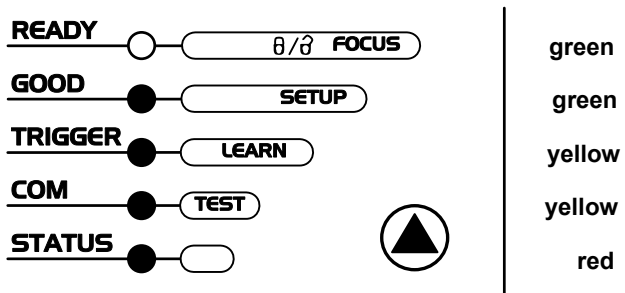

Figure 9 – X-PRESS™ Interface: Auto Setup Function

The procedure is as follows:

- A) **place** the desired barcode on the scanline.
- B) **enter** the AutoSetup function (the laser turns on and the SETUP LED blinks to indicate the ongoing process)
- C) **wait** until the SETUP LED stays steady on (indicating the reader has detected the barcode)

This procedure ends either when the barcode is successfully decoded or after a timeout of about 7 (seven) seconds.

The scanner will restart at the end of the process, and then the optimized reading parameters for that barcode are automatically configured in scanner memory.

Focus Lock/Unlock

You must perform the *Focus Lock* procedure to save the mechanical focus position to memory. If the mechanical focus position is changed by more than the allowed tolerance of the value in memory, a diagnostic alarm will be sent to the display.

1. Enter the Focus Lock function by holding the X-PRESS™ push button pressed until the FOCUS LOCK LED is on.
2. Release the button to enter the *Focus Lock* function.
Once entered, the scanner automatically performs the Lock (saving) or Unlock procedure depending on the previous state of the Locked Position parameter.

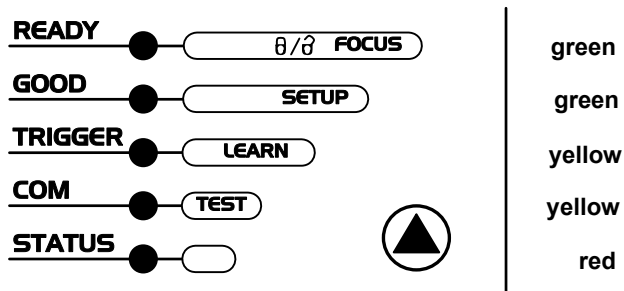

Figure 10 – X-PRESS™ Interface: Focus Lock/Unlock Function

The procedure is as follows:

- A) **enter** the Focus Lock function
- B) **wait** until the "Focus locked at..." message appears on the display (indicating the focus position has been saved to memory). The following parameters are set:
 - Locked Position = your mechanical setting
 - Focus Displacement (Alarm) = set (default to display only)

The scanner will restart at the end of the process.



NOTE

If your application has been configured using X-PRESS™, go to STEP 6.

Reset Scanner to Factory Default (Optional)

If it ever becomes necessary to reset the scanner to the factory default values, you can perform this procedure by holding the X-PRESS™ push button pressed while powering up the scanner. At the end of the procedure (about 5-6 seconds), the Configuration and Environmental parameters are reset, all LEDs blink simultaneously 3 times and the message "Default Set" is shown on the display.

STEP 5 – INSTALL GENIUS™ CONFIGURATION PROGRAM

Genius™ is a Datalogic scanner configuration tool providing several important advantages:

- Wizard approach for new users;
- Multi-language version;
- Defined configuration directly stored in the reader;
- Communication protocol independent from the physical interface allowing to consider the reader as a remote object to be configured and monitored.

To install Genius™, turn on the PC that will be used for the configuration, running Windows 98, 2000/NT, XP or Vista, then insert the Genius™ CD-ROM, wait for the CD to autorun and follow the installation procedure.

This configuration procedure assumes scanner connection to a CBX100/500. Genius™, running on a laptop computer, is connected to the scanner auxiliary port through the CBX100/500 9-pin connector. To communicate with the scanner, Genius™ performs an auto baudrate detection starting from its default parameters which are 115200, 8, N, 1. These parameters can also be set in the Genius™ Tools>Options>Communications window.

Wizard for Quick Reader Setup

After installing the Genius™ software program the following window appears asking the user to choose the desired configuration level.



Figure 11 - Genius™ Wizard Opening Window

The Wizard option is advised for rapid configuration or for new users, since it shows a step-by-step scanner configuration.

1. Select the *Create a new configuration* button.

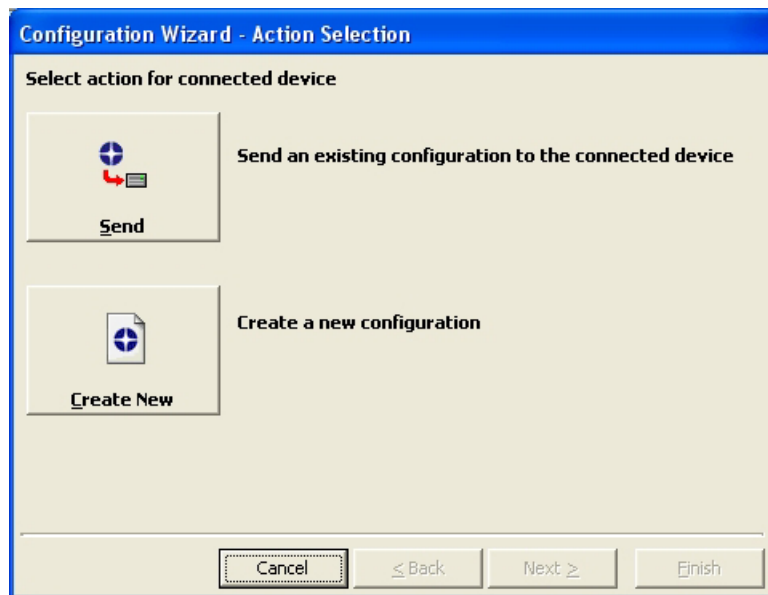

You will be guided through the configuration being asked to define the following parameters:

- a. Barcode selection and definition

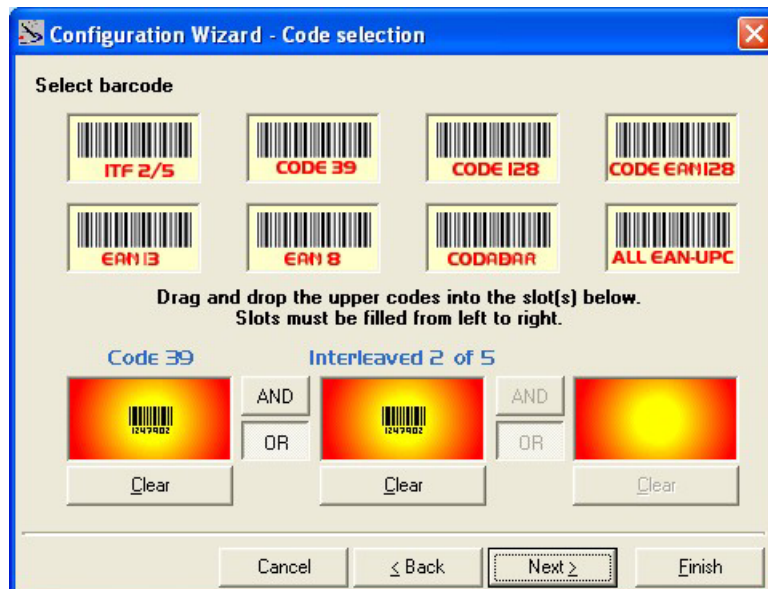

b. Operating mode selection and definition

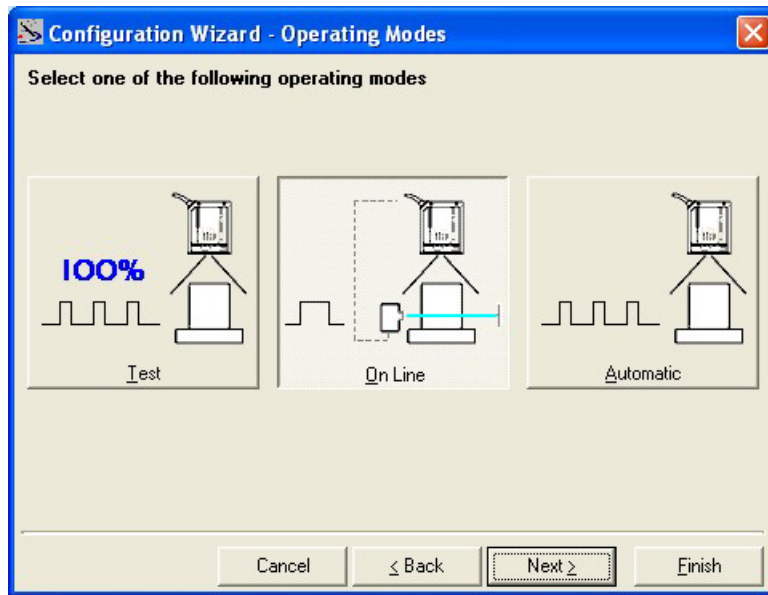

c. Digital Outputs configuration

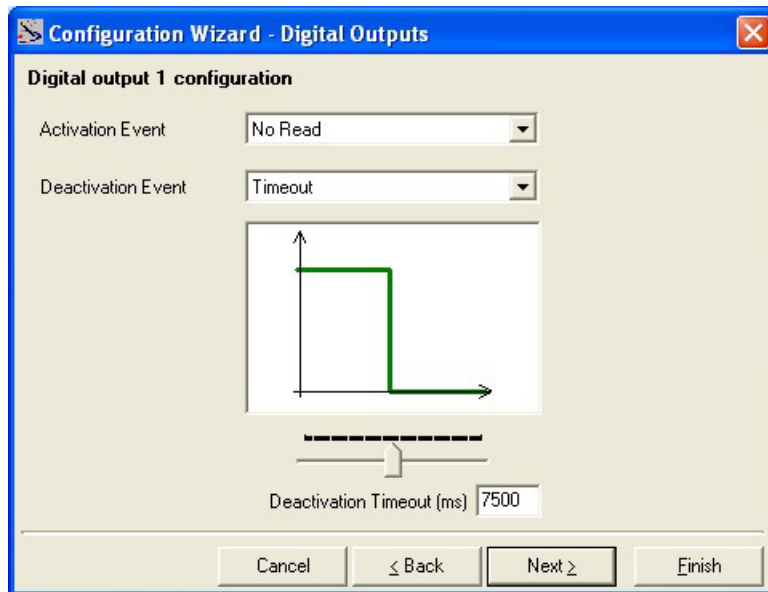

d. Hardware interface selection

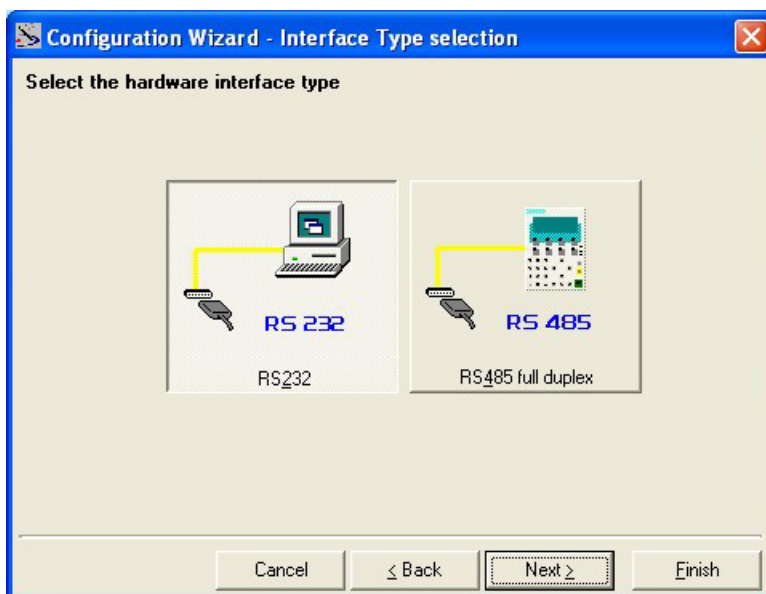

e. Output data format configuration

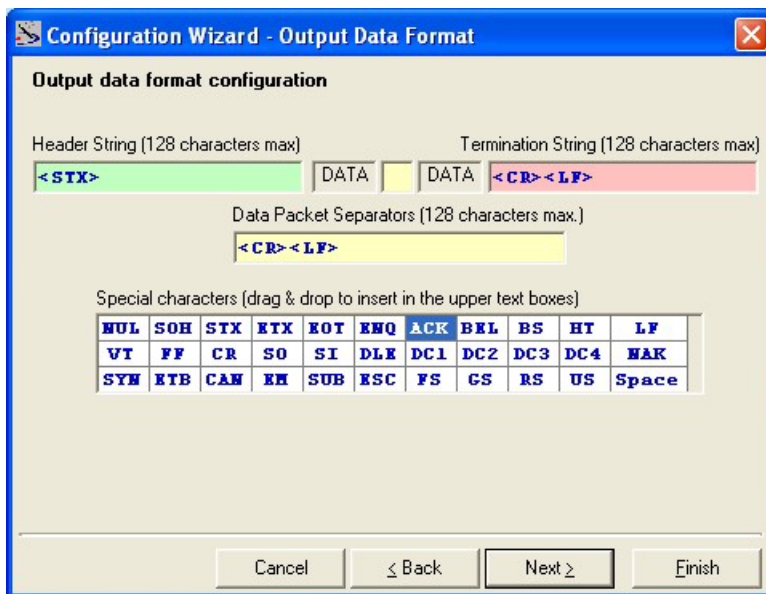

The **On Line** operating Mode requires the reader to be connected to an External Trigger/Presence Sensor using I1A and I1B inputs.

The **Automatic** operating mode does not require connection to an external Presence Sensor. When working in this mode the reader is continuously scanning, while the reading phase is activated each time a barcode enters the reader reading zone. The reader stops reading after an N number of scans without a code. Barcode characters are transmitted on the serial interface. In case of a failed reading phase no message is sent to the host computer.

2. After defining the parameter values the following window appears allowing to complete the reader configuration as follows:
 - Saving the configuration to disk;
 - Switching to Advanced mode;
 - Sending the configuration to the scanner.

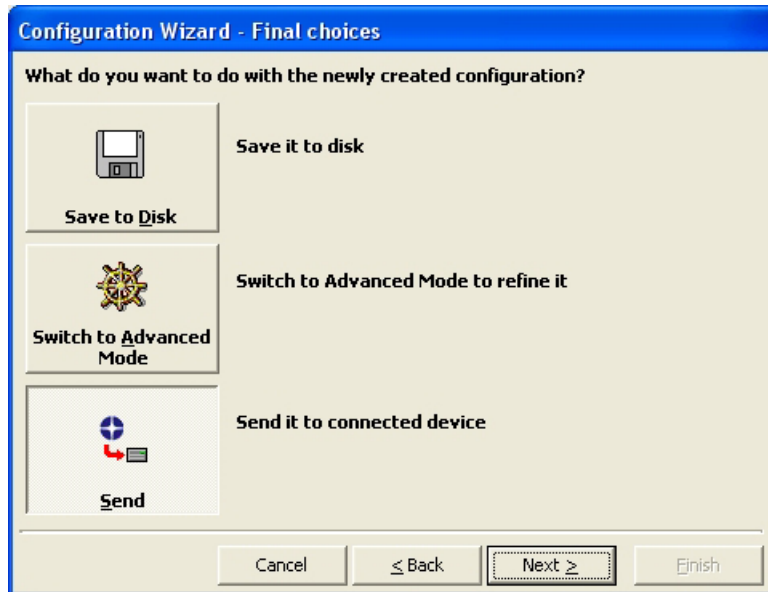

3. After sending the configuration to the scanner you have completed the configuration process.

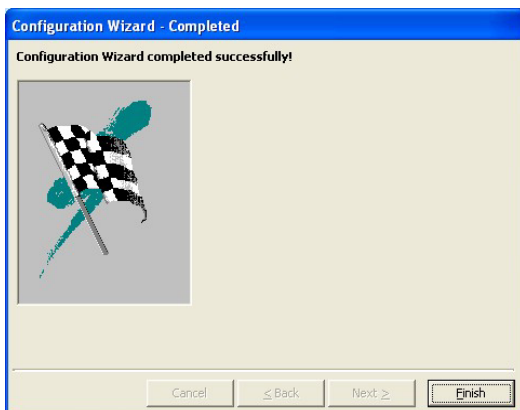

4. By clicking Finish, the System Information window will be displayed with specific information concerning the scanner.

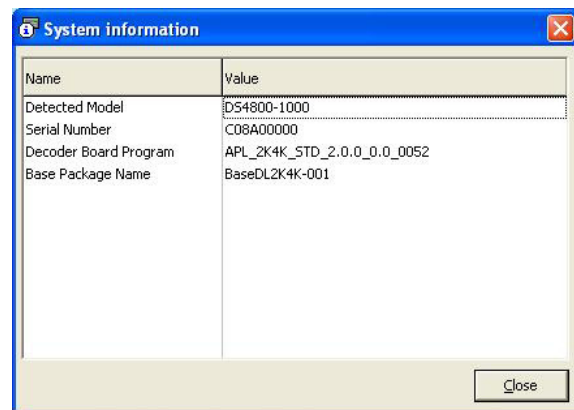

STEP 6 – TEST MODE



NOTE

When entering the X-PRESS™ interface on the DS4800-X1XX the Oscillating Mirror remains in the default **fixed position** (0°) in order to make barcode reading easier while performing the X-PRESS™ functions.

Use a code suitable to your application to test the system. Alternatively, you can use the Datalogic Test Chart (Code 128).

1. Enter the *Test mode* function by holding the X-PRESS™ push button pressed until the TEST LED is on.
2. Release the button to enter the *Test mode* function.
Once entered, the Bar-Graph on the five LEDs is activated and if the scanner starts reading barcodes the Bar-Graph shows the Good Read Rate. In case of no read condition, only the STATUS LED is on and blinks.

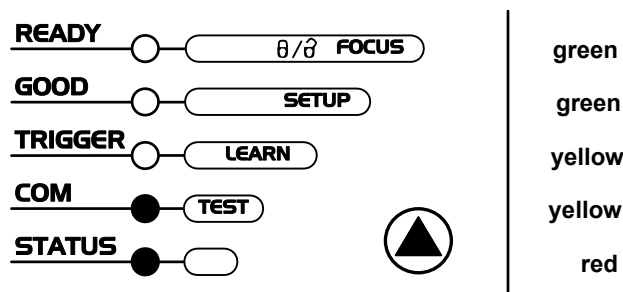

Figure 12 – X-PRESS™ Interface: Test Mode Function

3. To exit the Test Mode, press the X-PRESS™ push button once.



NOTE

By default, the Test Mode exits automatically after two minutes.

ADVANCED SCANNER CONFIGURATION

The ADVANCED selection available when starting the Genius™ program is addressed to expert users being able to complete a detailed scanner configuration. By choosing this option it is possible either to start a new scanner configuration or to open and modify an old one. The desired parameters can be defined in the following window, similar to the MS Explorer:

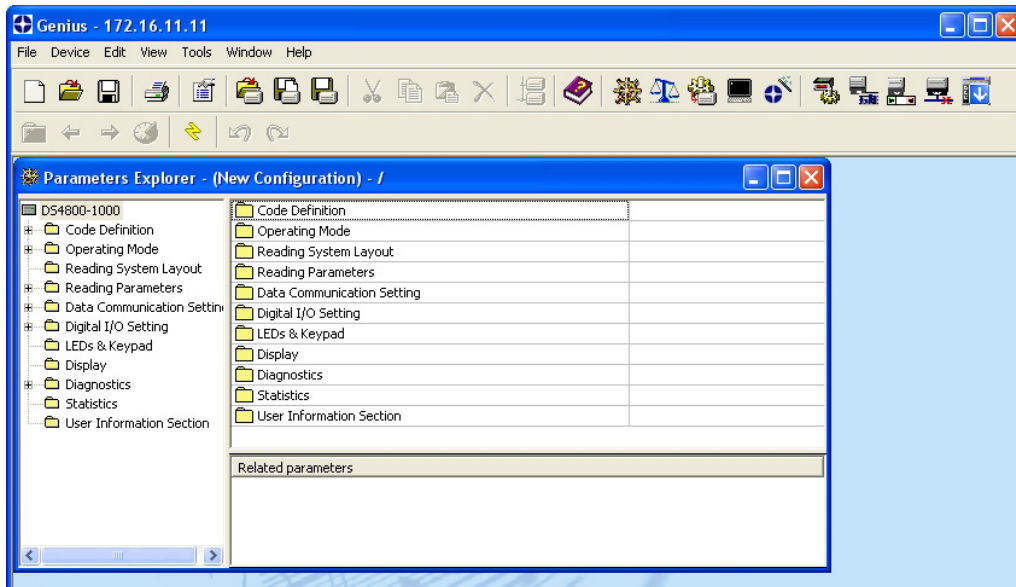

Figure 13 - Genius™ Parameter Explorer Window

Host Mode Programming

The scanner can also be configured from a host computer using the Host Mode programming procedure, by commands via the serial interface. See the Host Mode Programming file on the CD-ROM.

Alternative Layouts

- The ID-NET™ network is a built-in high-speed interface dedicated for high-speed scanner interconnection. ID-NET™ is in addition to the Main and Auxiliary serial interfaces. If you need to install an ID-NET™ network refer to the DS4800 Reference Manual.

The scanner can also be configured by reading programming barcodes. See the "Setup Procedure Using Programming Barcodes" printable from the CD-ROM.

- If you need to install an Ethernet network, Fieldbus network, Pass-Through network, Multiplexer network or an RS232 Master/Slave network refer to the DS4800 Reference Manual.

2 INTRODUCTION

2.1 PRODUCT DESCRIPTION

The DS4800 laser scanner satisfies the most advanced needs of a wide range of users. It has been developed focusing on the realistic requirements of its target market. The outstanding result is an extremely compact, cost-effective and easy to use industrial scanner.

Standard Application Program A standard application program is factory-loaded onto the DS4800. This program controls barcode reading, serial port interfacing, data formatting and many other operating and control parameters.

It is completely configurable from a host computer through the Genius™ utility program provided on CD with the scanner, or via the serial interface (Genius™ based Host Mode Programming).

Custom Application Programs If the Standard Application Program does not meet your requirements, please contact your local Datalogic distributor.

Some of the main features of DS4800 are listed below:

- ACR4™ (Advanced Code Reconstruction – 4th Generation)
- small dimensions and light weight
- software programmable scanning speed
- completely configurable via serial interface (Genius™)
- 3 serial communication interfaces (Main, Auxiliary, ID-NET™)
- supply voltage from 10 to 30 Vdc
- reads all popular codes
- test mode to verify the reading features and exact positioning of the scanner without the need for external tools
- programmable in 4 different operating modes to suit the most various barcode reading system requirements
- code verifier
- low power consumption

The DS4800 uses a solid-state laser diode as a light source; the light emitted has a wavelength between 630 and 680 nm. Refer to the section “Safety Precautions” at the beginning of this manual for information on laser safety.

The protection class of the enclosure is IP65, the reader is therefore suitable for industrial environments where high protection against harsh external conditions is required.

2.1.1 Indicators

The five LEDs on the side of the scanner ([Figure A, 3](#)) indicate the following:

LED	Color	Description
READY	Green	This LED indicates the device is ready to operate. For Subzero models this LED blinks during the warm-up phase.
GOOD	Green	This LED confirms successful reading.
TRIGGER	Yellow	This LED indicates the status of the reading phase. *
COM	Yellow	This LED indicates active communication on main serial port. **
STATUS	Red	This LED indicates a NO READ result.

* In On-Line mode the TRIGGER LED corresponds to the active reading phase signaled by the Presence Sensor. In Automatic and Continuous modes the TRIGGER LED is always on indicating that the reader is ready to read a code.

** When connected to a Fieldbus network through the CBX500, the COM LED is always active, even in the absence of data transmission, because of polling activity on the Fieldbus network.

During the reader startup (reset or restart phase), all the LEDs blink for one second.

On the back of the reader near the cable, the “POWER ON” LED indicates the laser scanner is correctly powered.

2.2 ID-NET™

The ID-NET™ network is a built-in high-speed interface dedicated for high-speed scanner interconnection. ID-NET™ is in addition to the Main and Auxiliary serial interfaces.



The following network configurations are available:

- **ID-NET™ M/S Synchronized:** Single station – multiple scanners

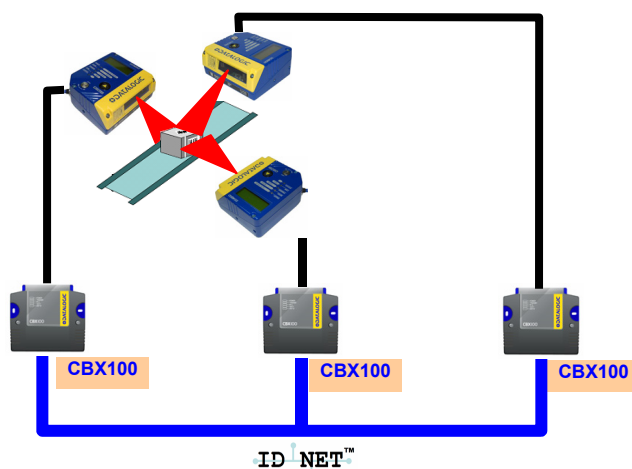

ID-NET™ interface allows local connection of multiple scanners reading different sides of the same target. All scanners share a single presence sensor and activate/deactivate simultaneously.

At the end of each reading phase a single data message is transmitted to the host.

Thanks to ID-NET™, data communication among scanners is highly efficient so that an immediate result will be available.

- **ID-NET™ M/S Multidata:** Multiple stations – single scanner

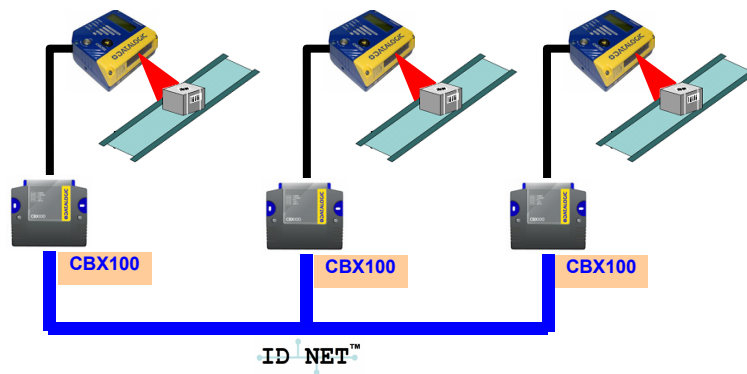

ID-NET™ interface allows connection of scanners reading objects placed on independent conveyors. All scanners are typically located far away from each other and they use a dedicated presence sensor.

At the end of each reading phase, each scanner transmits its own data message to the host.

Thanks to ID-NET™, data collection among readers is accomplished at a high speed without the need of an external multiplexing device. This leads to an overall cost reduction and to a simple system wiring.

2.2.1 How To Setup/Configure the Scanner Network

A complete ID-NET™ scanner network can be rapidly setup, as follows:

Mounting & Connection

1. Mechanically mount/install all the readers (refer to par. 3.2 and 3.3).
2. Wire ID-NET™ (refer to par. 4.3 or 5.3).
3. Connect a PC equipped with Genius™ to the planned Master scanner.
4. Power up the entire system.

Configuration

1. Launch Genius™.
2. From the Genius™ Device Menu select "Local Device Network Settings" and program the Role of the Master scanner (Synchronized or Multidata).

This procedure requires the Network Baud Rate be the same for all Slaves and Master, (500 kbs is the default value). It can be changed after network setup using Genius™ through the Master scanner. See also the alternative procedure in the note below.

3. At the prompt to "Send updated Network configuration to the Local Device" (Master) choose "Yes".
4. Then run the NET-AUTOSET procedure from the Icon in the Devices Area. Genius™ sets all slave scanners according to the Master Role (Synchronized or Multidata), and assigns each a random address. If necessary, this address can be changed through the Network Wizard.
5. Configure the System parameters via Genius™.
6. If using the CBX connection box equipped with a BM100 Backup module, perform System Backup at the Master.

The scanner network is ready.

**NOTE**

If necessary, the ID-NET™ baudrate can be set individually on each Slave scanner to match the Master. Connect each Slave to Genius™ and set the Reading System Layout > Network Baudrate parameter. Then follow the procedure above.

**NOTE**

An alternative method of programming scanner address and role assignment can be accomplished by using the "Connectivity Programming Barcodes" (refer to the "Setup Procedure Using Programming Barcodes" document on the product CD).

2.3 X-PRESS™ HUMAN MACHINE INTERFACE

X-PRESS™ is the intuitive Human Machine Interface designed with the precise goal of improving ease of installation and maintenance.

Status and diagnostic information are clearly presented by means of five-colored LEDs, whereas the single multi-function key gives immediate access to relevant functions:

- *Autosetup* to self-optimize reading performance in demanding applications
- *Autolearn* to self-detect unknown barcodes
- *Focus Lock* to memorize the mechanical focus position
- *Test Mode* with bar-graph visualization to check static reading performance

Xpress
interface



X-PRESS™ is the common interface adopted in all new products: “*You learn one, you can use them all*”.

The colors and meaning of the five LEDs when in the one of the operating modes (On-Line, Automatic or Continuous) are illustrated in par 2.1.1.



NOTE

Except for the Focus Lock/Unlock function, the X-PRESS™ functions do not work if the motor or laser are turned off, see chp. 9 for details.

2.3.1 Diagnostic Indication

The “STATUS” and “READY” LEDs blink simultaneously to signal the presence of a failure. Diagnostic message can be enabled to provide details about specific failure conditions. These messages will be shown on the display and if enabled for transmission, also on the selected interfaces.

At the same time one or more LEDs light up according to the following scheme:

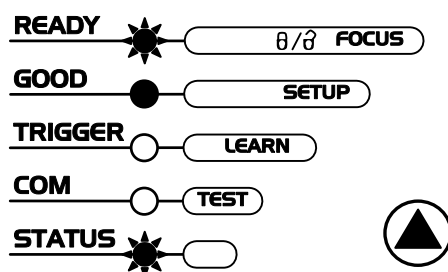

LED	STATUS
READY	BLINK
GOOD	ON to indicate any Failure different than Motor or Laser failures.
TRIGGER	ON to indicate a Motor Failure.
COM	ON to indicate a Laser Failure.
STATUS	BLINK

DS4800 also shows specific diagnostic messages on its display, see par. 2.4 for details.

2.3.2 X-PRESS™ Functions

Quick access to the following functions is provided by an easy procedure using the push button:

- 1 – **Press** the button (the STATUS LED will give a visual feedback).
- 2 – **Hold** the button until the specific function LED is on (TEST, LEARN or SETUP).
- 3 – **Release** the button to enter the specific function.

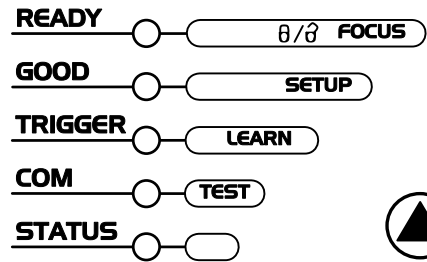

Once button is pressed, the cycle of LEDs activation is as follows:

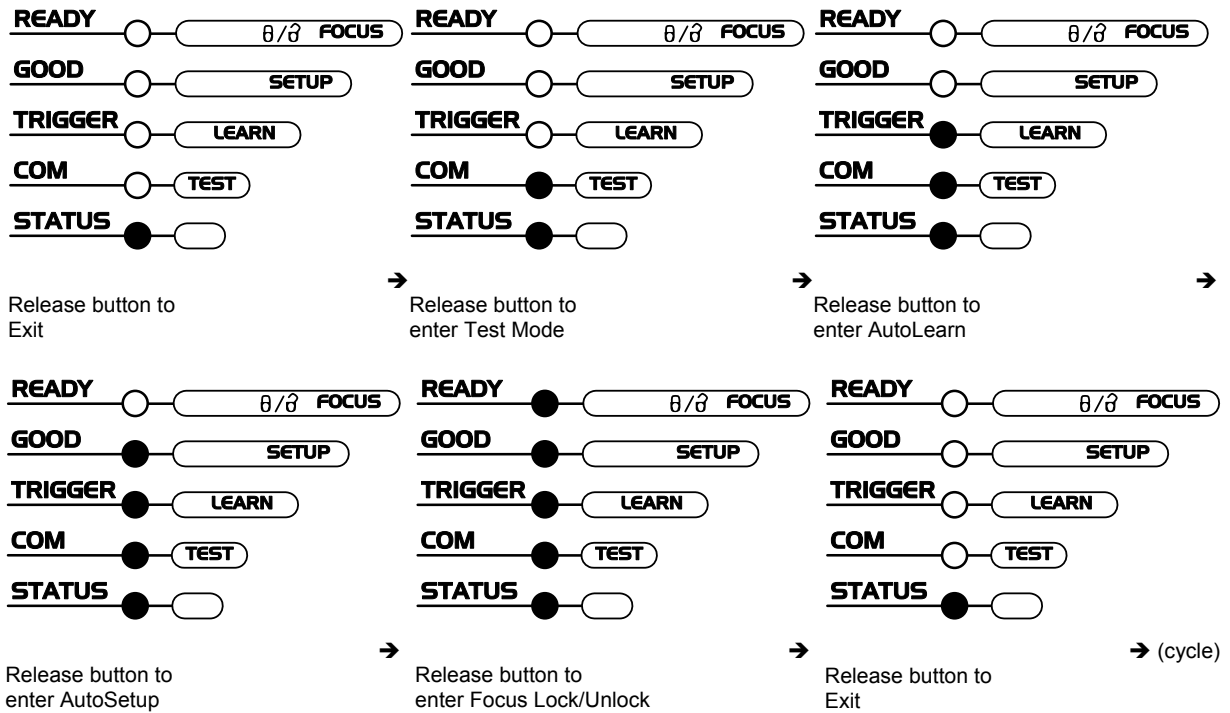

Test Mode Function

Once entered, the Bar-Graph on the five LEDs is activated and if the scanner starts reading barcodes the Bar-Graph shows the Good Read Rate. In case of no read condition, only the STATUS LED is on and blinks.

To exit the Test Mode, press the X-PRESS™ push button once.

AutoLearn Function

Once entered, the reader starts a procedure to automatically detect and recognize barcodes (by type and length), which are presented to it¹. The laser turns on and the LEARN LED blinks to indicate the ongoing process.

The procedure is as follows:

- **place** the desired barcode on the scanline.
- **wait** until the LEARN LED stays steady on (indicating the reader has detected the barcode).
- **repeat**, if needed, the above two steps to program up to 10 different barcodes (the LEARN LED returns to the blinking state for the next code). If more than one barcode is detected in the scan line, the Multi Label mode is enabled (refer to the “*2K/4K Family Software Configuration Parameter Guide*” Help file).
- **exit** the process by pressing the X-PRESS™ push button once.

The scanner will restart at the end of the process, and then the detected barcodes are automatically configured in scanner memory.

AutoSetup Function

Once entered, if a barcode label is positioned in front of the scanline, the scanner automatically performs the optimal setup of the reading parameters for that specific barcode.

The procedure is as follows:

- **place** the desired barcode on the scanline.
- **enter** the *AutoSetup* function (the laser turns on and the SETUP LED blinks to indicate the ongoing process).
- **wait** until the SETUP LED stays steady on (indicating the reader has detected the barcode).

This procedure ends either when the barcode is successfully decoded or after a timeout of about 7 (seven) seconds.

The scanner will restart at the end of the process, and then the optimized reading parameters for that barcode are automatically configured in scanner memory.



NOTE

The AutoSetup function does not modify the programmed barcode symbologies. If needed, the AutoLearn function can be performed after AutoSetup.

¹ In case of Programming Barcodes, refer to the “Setup Procedure Using Programming Barcodes” document in the product CD.

Focus Lock/Unlock

Once entered, the scanner automatically performs the *Focus Lock* procedure to save the mechanical focus position to memory. If the mechanical focus position is changed by more than the allowed tolerance of the value in memory, a diagnostic alarm will be sent to the display.

The procedure is as follows:

- **enter** the Focus Lock function.
- **wait** until the "Focus locked at..." message appears on the display (indicating the focus position has been saved to memory). The following parameters are set:
 - Locked Position = your mechanical setting
 - Focus Displacement (Alarm) = set (default to display only)

If the Focus lock has already been set, this procedure can be used to Unlock the focus value. In this case control of the focus position is disabled.

The scanner will restart at the end of the process.

Reset Scanner to Factory Default

If it ever becomes necessary to reset the scanner to the factory default values, you can perform this procedure by holding the X-PRESS™ push button pressed while powering up the scanner. At the end of the procedure (about 5-6 seconds), the Configuration and Environmental parameters are reset, all LEDs blink simultaneously 3 times and the message "Default Set" is shown on the display.

2.4 DISPLAY

The DS4800 is equipped with a 2 line by 16 character LCD display which shows various diagnostic, menu and operating mode messages according to a defined priority (0 = top priority):

Priority	Message Type
0:	File Transfer, Backup & Restore, Restore Default Parameters
1:	X-PRESS™ Menu Selection
2:	Focus Setup Procedure
3:	Diagnostic Alarms *
4:	Reading Results
5:	Welcome Message ²

* Diagnostic Alarm Messages can be enabled/disabled in Genius™.

² For Master devices only, Network Diagnostics can be enabled through the Network Status Monitor parameter in Genius™ instead of the Welcome Message.

The display language for messages can be selected in Genius™. The currently supported languages are:

- English (default)
- French
- German
- Italian
- Japanese

2.4.1 Display Messages

The following examples of DS4800 Local Display messages are given to help interpret the information reported.

Test Mode Results:

```
A A A %      Z Z Z Z Z Z Z Z Z Z Z Z
F = X X X c m    -   Y Y . Y i n
```

A = reading percentage from 000 to 100%.

Z = code content.

F = focus distance in given in centimetres and inches.

Autolearn Results:

```
X X X X X X X X X X      Y Y D G T
A u t o l e a r n    O k # Z Z
```

X = recognized code symbology.

Y = number of digits in the read code

Z = number of configured slot (at the end of the procedure this number represents the total slots configured).

Diagnostic Alarms:

```
A l e r t      : M o t o r
S p e e d     = X X X X / Y Y Y Y
```

X = expected speed

Y = actual speed

Generic Alarms:

```
A l e r t      :
F a i l u r e   # X X X
```

X = numeric error value (even if User Defined Messages are selected for data transmission the numeric error value is sent to the display)

Slave Node Alarms:

```

A l e r t      : I D - N E T
N o d e # X X   F a i l # Y Y Y

```

X = slave node number (1-31)

Y = numeric error value

Reading Results:

```

A A A A      X X X X X X X X X X X X
Y Y C o d e s

```

A = reading result – Good (Good Read), Part (Partial Read), Mult (Multiple Read)

X = code content

Y = number of codes read

```

G o o d      X X X X X X X X X X X X
Y Y      D G T      D      W W W      S S S

```

X = code content

Y = number of digits in the code

DGT = "digits"

D = code direction – F=forward, R=reverse, U=unknown

Linear Reading (only if the Quality Counters parameter is enabled)

W = number of scans on the code

S = Quality Counters value (max 100)

Code Reconstruction

W = number of scans on the code (max 255)

S = number of decodes (max 255), on the digit in the code which was decoded the least number of times

Welcome Message:

The display alternates between message 1 and 2.

Message 1

```
X X X X X X X X X X X X X R R R
K K K Y Y Y Y Y Y Y Y Y Y N N N
```

X = scanner model

K = software – STD=Standard, SS=Special

Y = software version

R = Device Network Type – MUL=Multidata, SYN=Synchronized, ALN=Alone, MUX=Slave Mux32, MST=Master RS232, SLV=Slave RS232

N = Device Network Setting – M00=ID-NET™ Network Master, Sxx= ID-NET™ Network Slave address, Axx= Mux32 Slave address, 232= RS232 network, Null string= Alone (no network)

Message 2

```
S N X X X X X X X X X X
F = Z Z Z C M - Y Y . Y I N
```

X = device serial number

Z = focus position in cm

Y = focus position in inches

Network Diagnostic Messages (Master only):

The display alternates between message 1 and 2.

Message 1

```
1 N e t w o r k 1 5
S S S S S S S S S S S S S S S S
```

Message 2

```
1 6 N e t w o r k 3 1
S S S S S S S S S S S S S S S S
```

S = Slave diagnostic condition:

* = scanner OK

- =scanner not detected at startup

? =scanner detected at startup but not responding to diagnostic polling

! = scanner diagnostic error

2.5 OSCILLATING MIRROR MODELS

The DS4800 OM is completely software controlled and software programmable through Genius™ which allows adjusting the oscillating frequency and the minimum and maximum oscillation angles of two separate reading zones.

When the oscillating mirror is programmed to read barcode labels at small angles, position the reader to **assure at least 15°** for the Skew angle. This angle refers to the most inclined or external laser line, so that all other laser lines assure more than 15° Skew. This avoids the direct reflection of the laser light emitted by the reader.

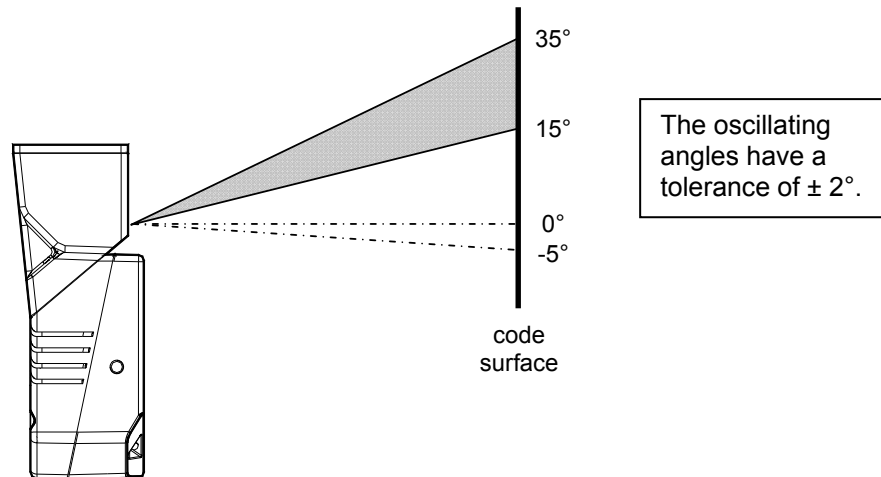

Figure 5 – Oscillating Mirror Skew Angle

Otherwise, the scanner can be mounted at an angle of inclination of 15° in order to attain symmetrical deflection ranges.

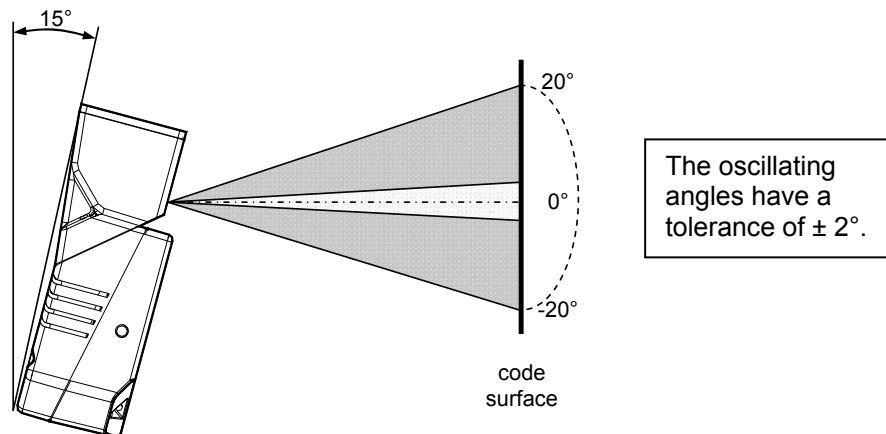

Figure 6 - Oscillating Mirror Reading Position

In the above case, the zone where the scan line is perpendicular to the reflecting surface corresponds to a neutral zone at the center of the reading field.



NOTE

By limiting the raster width to the minimum necessary, the number of scans on the reading surface is increased.

2.6 SUBZERO TEMPERATURE MODELS

The DS4800 Subzero scanner is an industrial scanner designed to operate in industrial refrigerator/freezer cells or other stable subzero degree environments, which are below the operating range of standard industrial scanners. It is not designed to move between subzero and normal environments (rapid temperature changes).

It has a patent-pending intelligent microprocessor-driven and very efficient internal heating system which constantly monitors and automatically controls internal temperature, heating only the necessary temperature-sensitive components and thereby keeping them functioning within their designed operating range even though the outside temperature is below this value. This results in very low overall power consumption. Part of this system also heats the Laser Beam Output window to eliminate ice and/or condensation build-up from negatively affecting the reading results.

Upon power-up in a subzero environment, the scanner waits until these internal components are heated to within their operating temperature range. For example, power-up at $-35\text{ }^{\circ}\text{C}$ can take about 20 minutes before the scanner is ready to read barcodes. During this time the laser, motor, and display remain off and the Ready LED blinks, indicating the warm-up phase. Scanner communication is however operative and it can be configured through Genius™ or through Host Mode Programming during this phase.

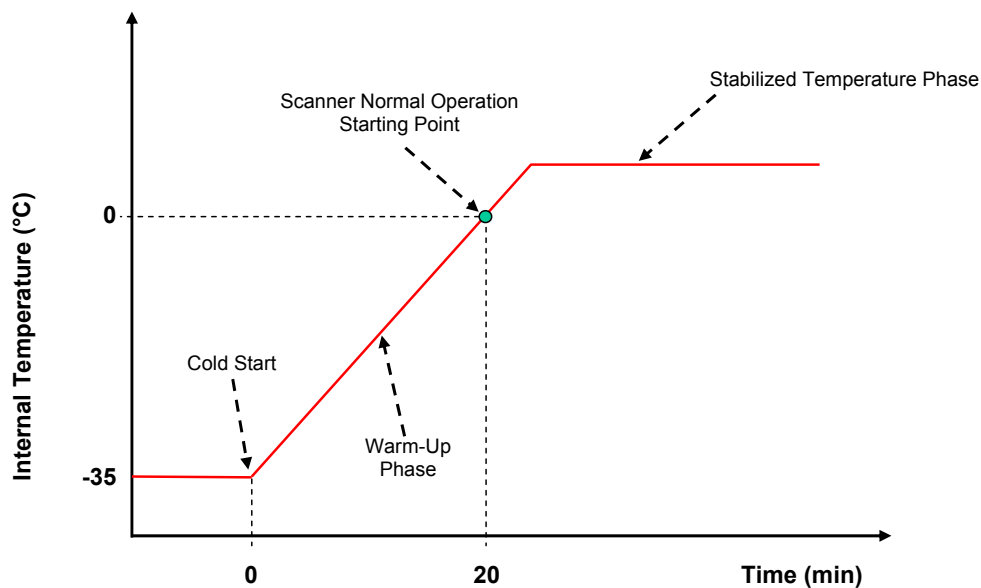

It can be connected to the CBX100 LT subzero connection box which can also withstand the same subzero environment.

2.7 MODEL DESCRIPTION

The DS4800 scanner is available in versions that differ in regard to the following parameters:

- Optical Model
- Special Features

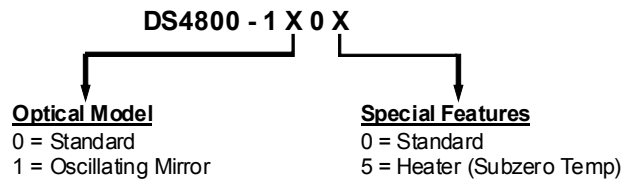

2.8 ACCESSORIES

The following accessories are available on request for the DS4800:

Name	Description	Part Number
Mirrors		
GFC-40	105° Deflection Mirror (only for DS4800-1000 Standard readers)	93ACC1785
Brackets		
BK-4000	L-Shape Bracket	93ACC1837
BK-4001	U-Shape Bracket	93ACC1838
Connection Boxes		
CBX100	Compact Connection Box	93A301067
CBX100 LT	Compact Connection Box Subzero (for DS4800 Subzero readers)	93A301069
CBX500	Modular Connection Box	93A301068
BM100	Backup Module	93ACC1808
BM150	CBX500 Display Module	93ACC1809
BM200/210	Ethernet TCP/IP Module STD/IP65	93ACC1851, 93ACC1852
BM300/310	Profibus Module STD/IP65	93ACC1810, 93ACC1811
BM400	DeviceNet Module IP65	93ACC1814
BM500/510/520	Ethernet/IP Module STD/IP65/IP54	93ACC1812, 93ACC1813, 93ACC1840
BM600	CANopen Module	93ACC1815
BM700	Profinet Module	93ACC1816
BM1100	CC-Link Module	93ACC1845
BM1200/1210	Modbus TCP	93ACC1848, 93ACC1849
BA100	DIN Rail Adapters	93ACC1821
BA200	Bosch Adapters	93ACC1822
BA900	Two Cable Glands Panel	93ACC1847
QL100	Quick Link Slave ID-NET T-Connector	93ACC1860
QL150	Quick Link Slave ID-NET + Service T-Connector	93ACC1868
QL200	Quick Link Slave ID-NET + Power T-Connector	93ACC1861
QL300	Quick Link Master ID-NET Serial Host Connector	93ACC1862
QL500	Quick Link Master ID-NET Ethernet Host Connector	93ACC1864

Sensors		
MEP-593	Photocell Kit - PNP (PH-1)	93ACC1791
MEP-543	Photocell Kit - NPN	93ACC1728
Power Supplies		
PG-6000/6001/6002	24 V Power Supply Unit EU/UK/US	93ACC1720, 93ACC1719, 93ACC1718

3 INSTALLATION

3.1 PACKAGE CONTENTS

Verify that the DS4800 reader and all the parts supplied with the equipment are present and intact when opening the packaging; the list of parts includes:

- DS4800 reader with cable
- DS4800 Quick Guide
- Barcode Test Chart (Grade A)
- Genius™ CD-ROM
- Mounting Kit:
 - bracket
 - screws
 - flat washers
 - lock washers

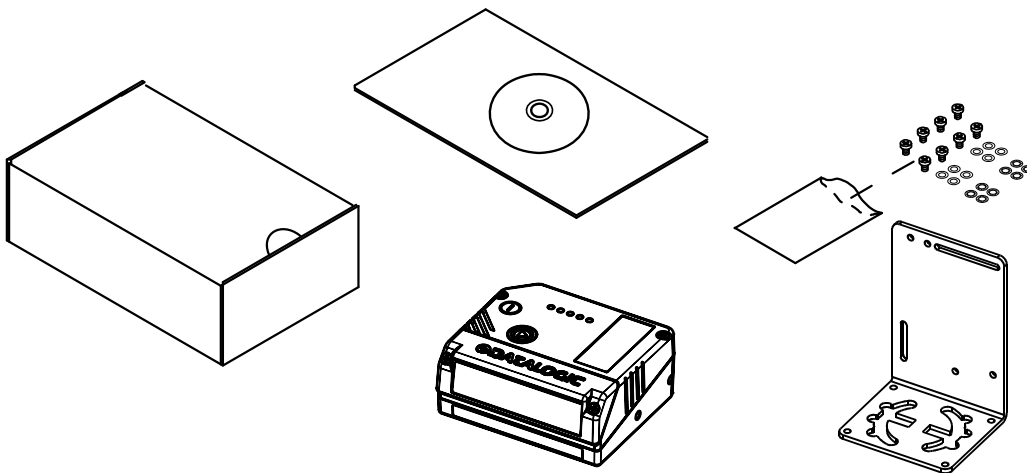

Figure 14- DS4800 Package Contents

3.2 MECHANICAL INSTALLATION

DS4800 can be installed to operate in different positions. The four screw holes (M4 x 5) on the body of the reader are for mechanical fixture to the L-shaped mounting bracket.

There are also three screw holes (M5 x 3) for fixture to the U-shaped mounting bracket.

The following diagrams give the overall dimensions of the scanner and mounting brackets and may be used for installation. Refer to par. 3.2.1 and 3.3 for correct positioning.

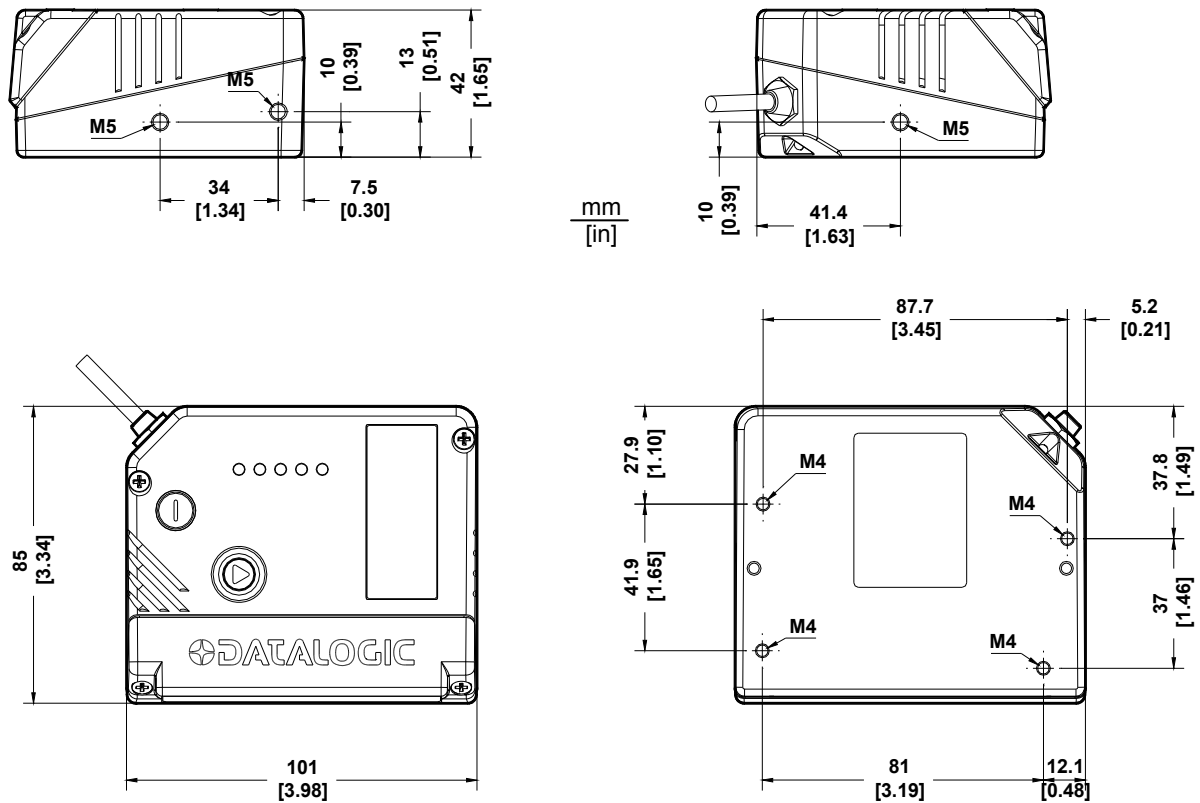

Figure 15 – DS4800 Overall Dimensions

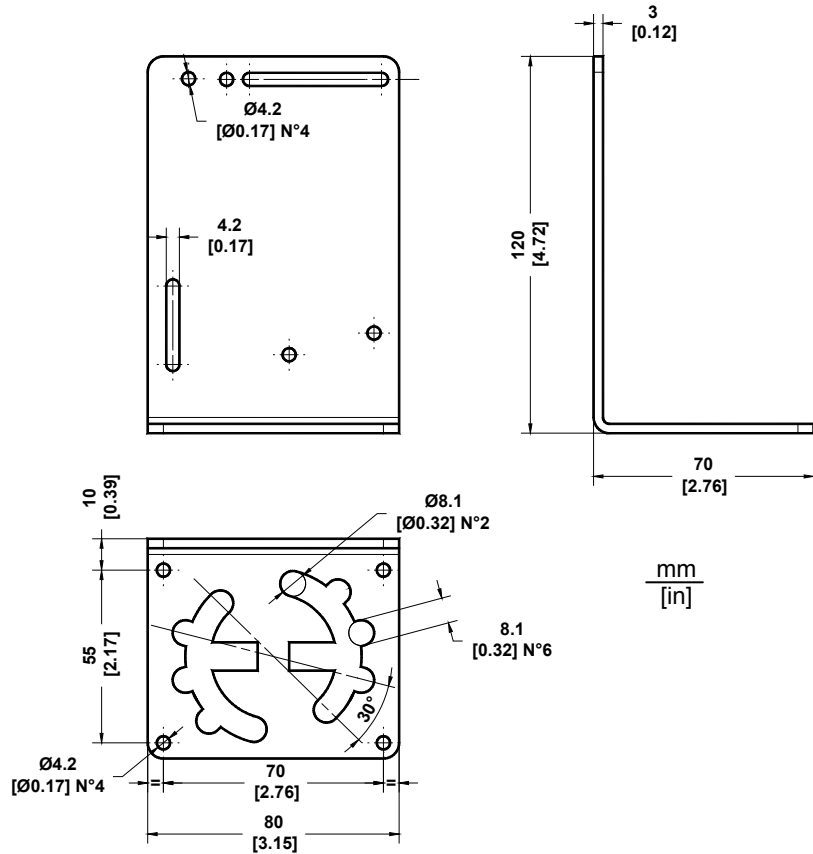

Figure 16 – L Shape Mounting Bracket Overall Dimensions

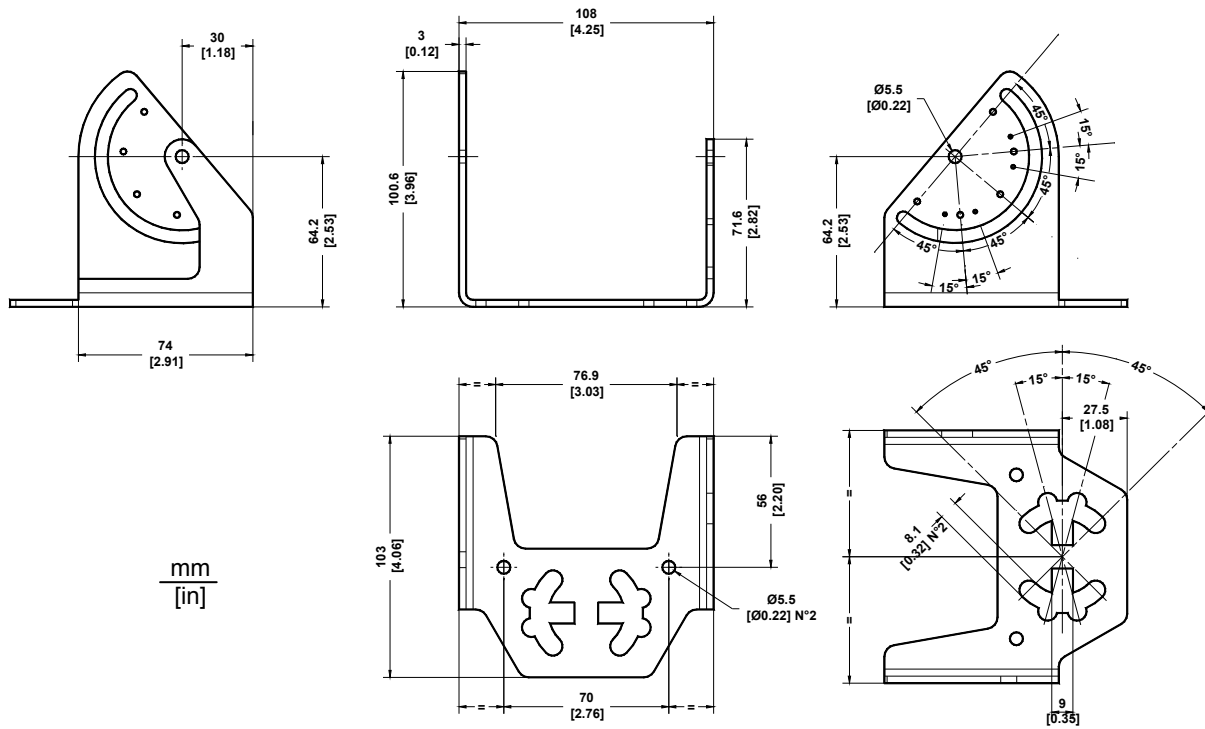

Figure 17 – U Shape Mounting Bracket Overall Dimensions

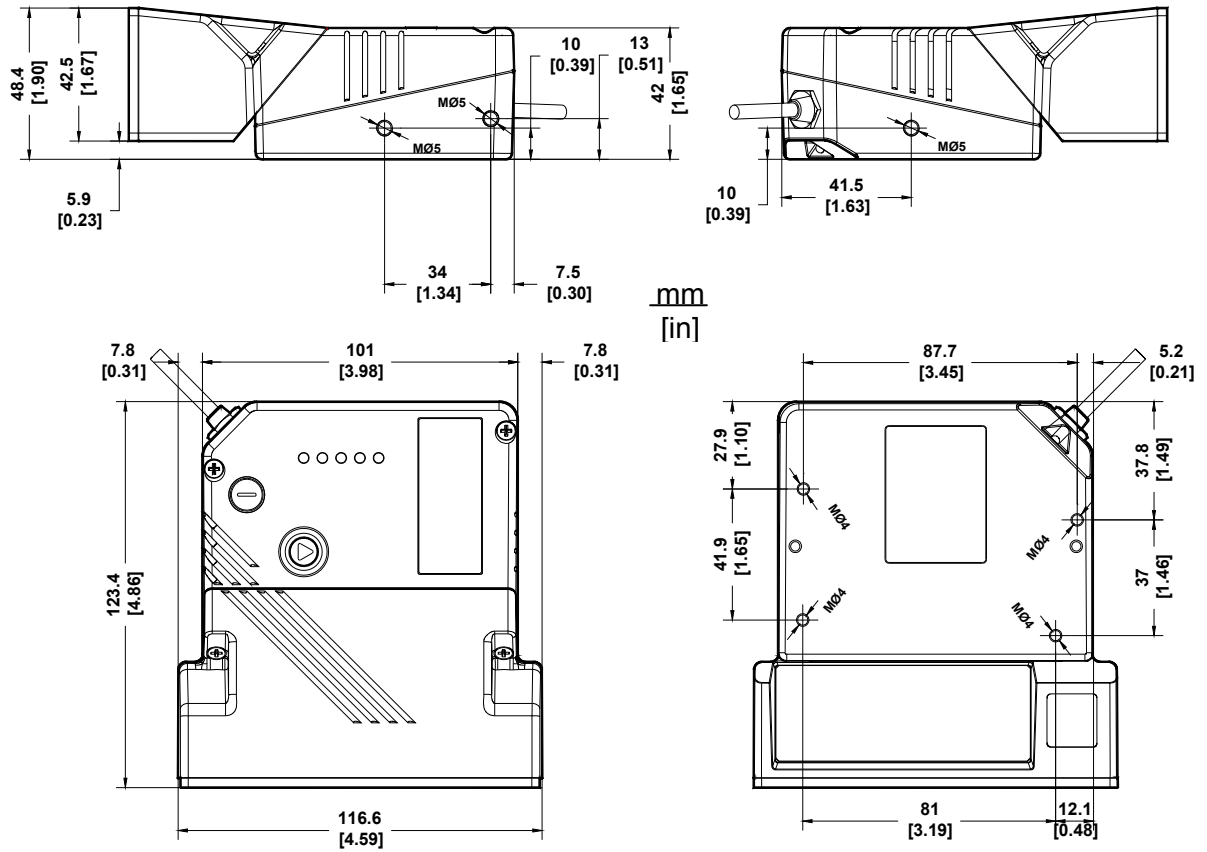

Figure 18 – DS4800 OM Overall Dimensions

3.2.1 Mounting DS4800

Using the DS4800 mounting bracket you can quickly and easily obtain standard mounting positions (i.e. 15° Skew angles) for the reader as shown in the following figures:

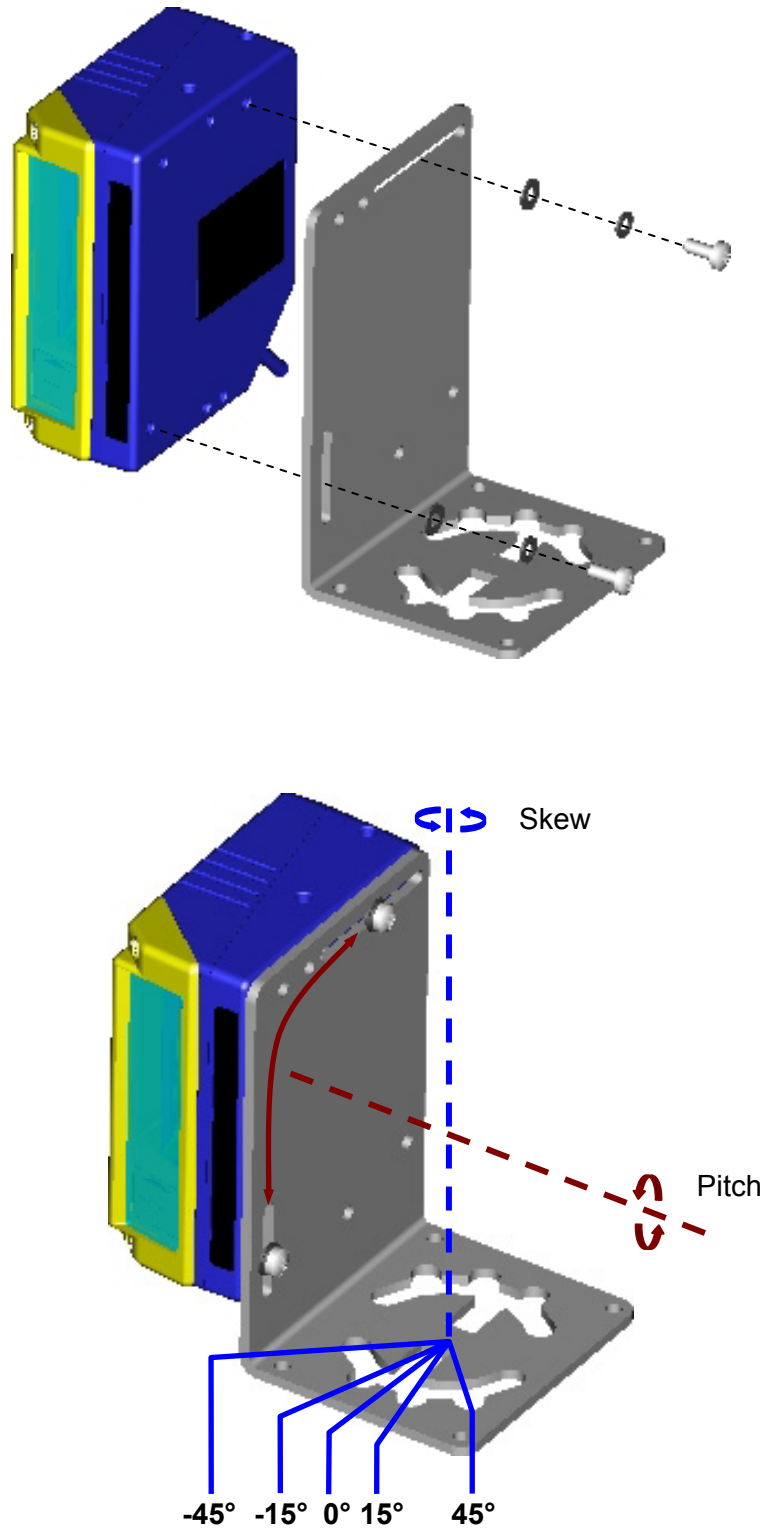

Figure 19 – Positioning with L Shape Mounting Bracket

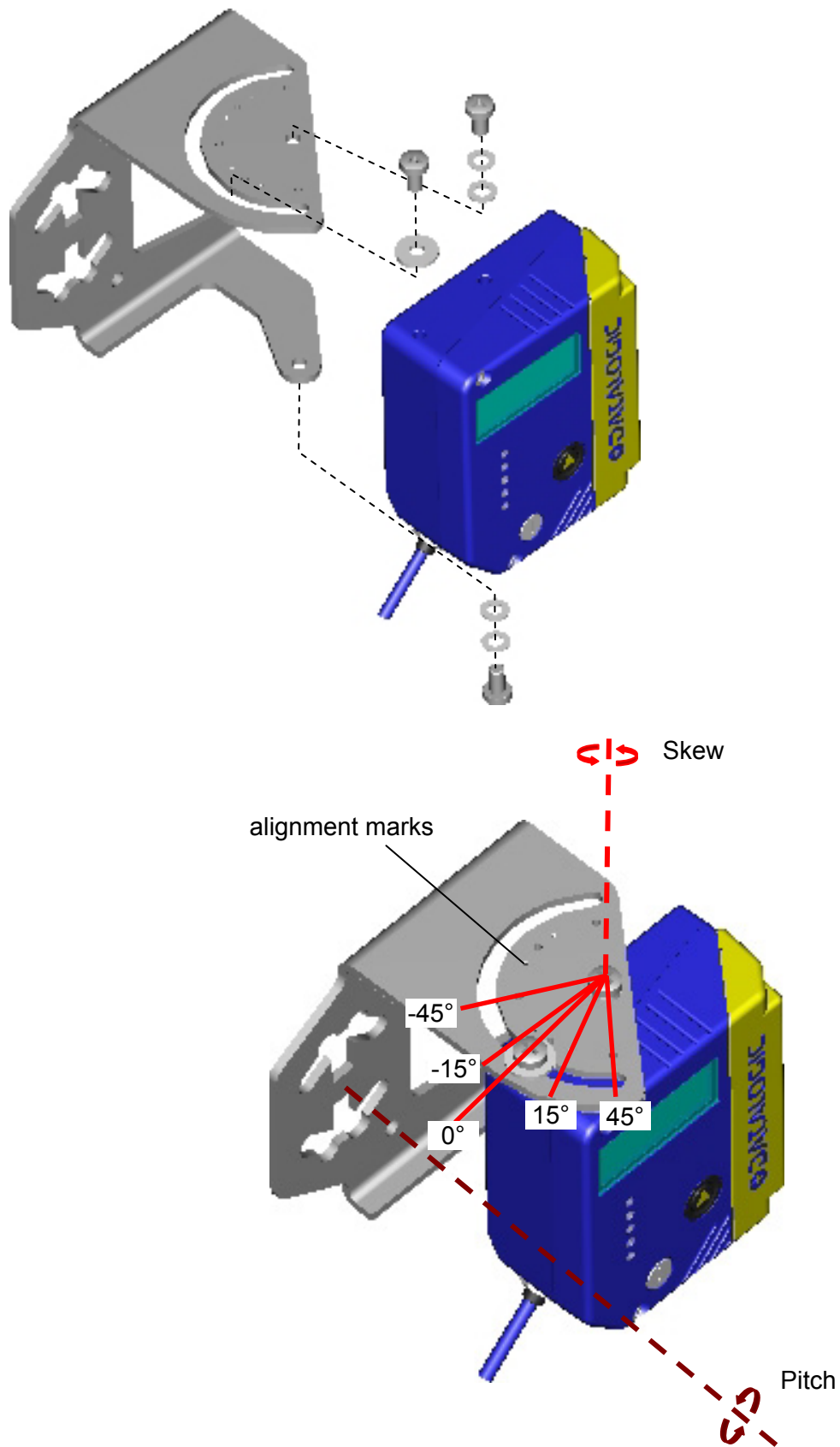

Figure 20 – Positioning with U Shape Mounting Bracket

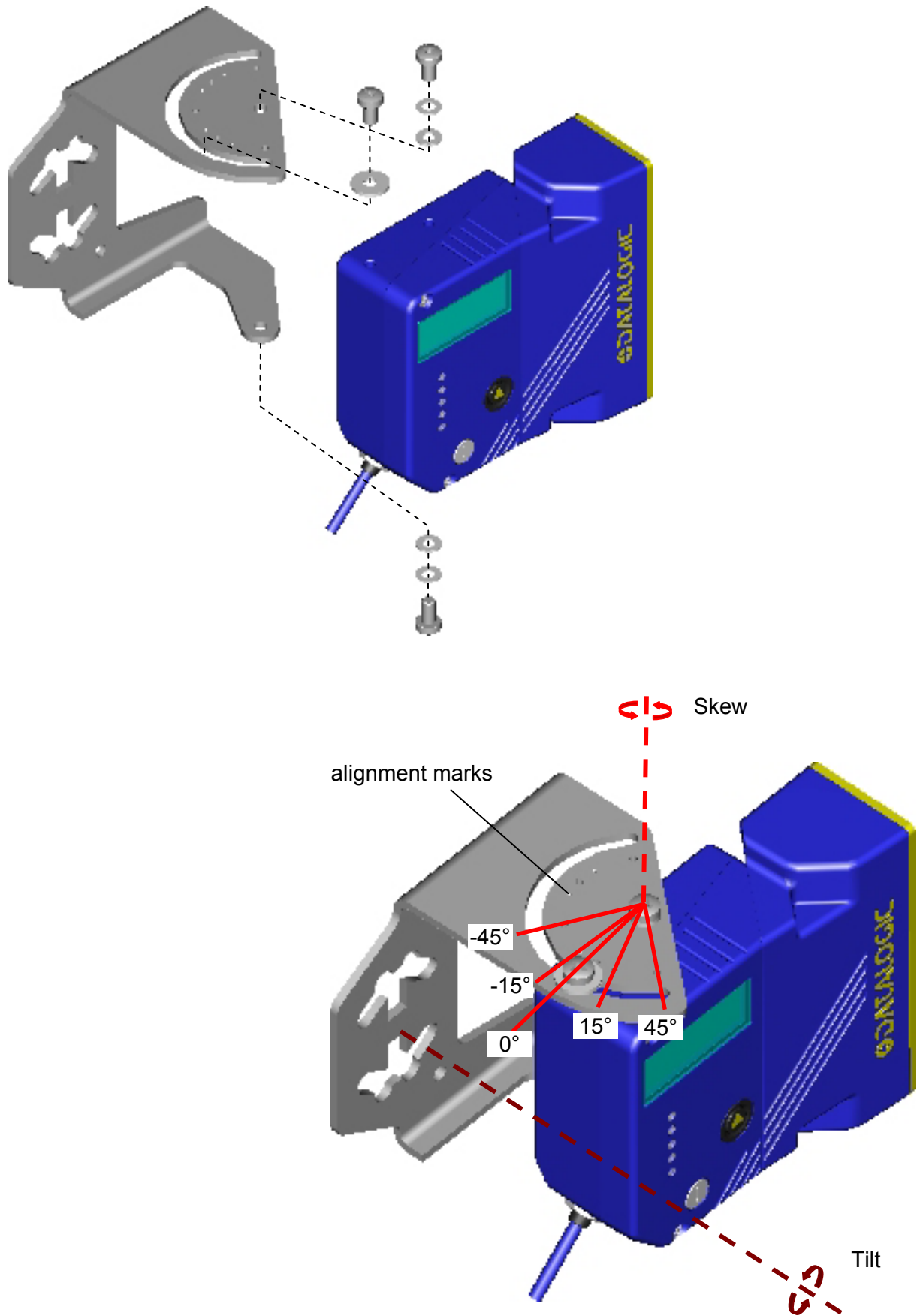

Figure 21 – DS4800 OM Positioning with U Shape Mounting Bracket

3.3 POSITIONING

The DS4800 scanner is able to decode moving barcode labels at a variety of angles, however significant angular distortion may degrade reading performance.

When mounting the DS4800 take into consideration these three ideal label position angles: **Skew 15° to 30°, Tilt 0° and Pitch 0°.**

Follow the suggestions for the best orientation:

The **Skew** angle is represented by the value **S** in Figure 22. Position the reader to **assure at least 15°** for the **Skew** angle. This avoids the direct reflection of the laser light emitted by the DS4800.

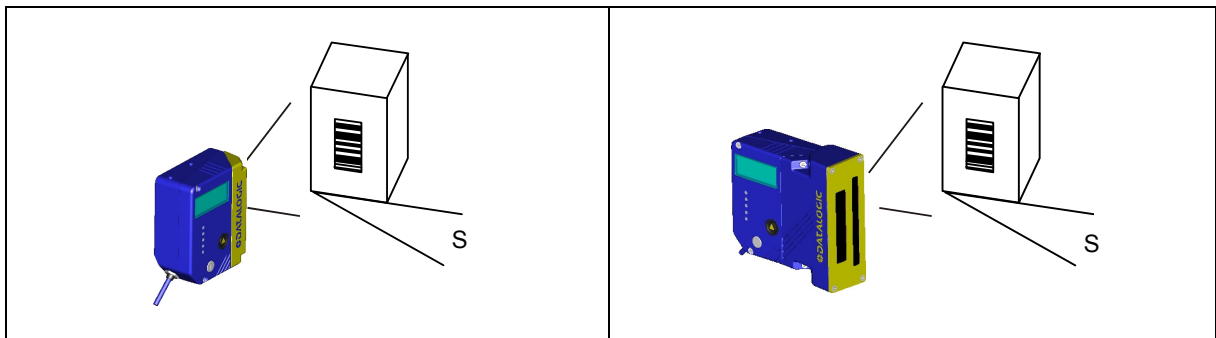

Figure 22 – DS4800 Skew Angle

The **Tilt** angle is represented by the value **T** in Figure 23. Position the reader in order to **minimize** the **Tilt** angle.

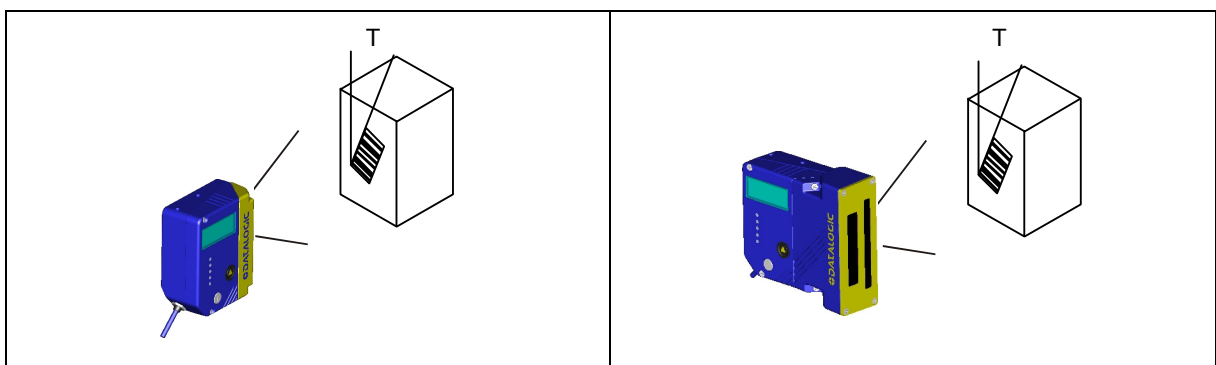

Figure 23 – DS4800 Tilt Angle

By using the ACR4™ (Advanced Code Reconstruction) software parameter, the tilt angle is less critical and can be decoded even if the scan line doesn't cross the entire code.

See par. 7.1 or the Help On Line for details.

The **Pitch** angle is represented by the value **P** in Figure 24. Position the reader in order to **minimize** the **Pitch** angle.

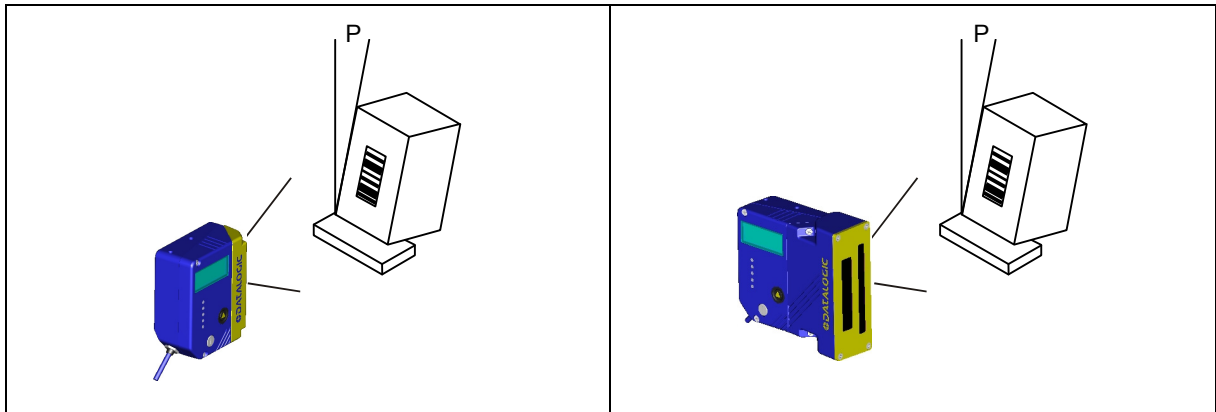

Figure 24 – DS4800 Pitch Angle

4 CBX ELECTRICAL CONNECTIONS

All DS4800 models are equipped with a cable terminated by a 25-pin male D-sub connector for connection to the power supply and input/output signals.

We recommend making system connections through one of the CBX connection boxes since they offer the advantages of easy connection, easy device replacement and filtered reference signals.



NOTE

If you require direct wiring to the scanner the details of the connector pins and relative connections are indicated in Chapter 5.

The table below gives the pinout of the CBX100/500 terminal block connectors. Use this pinout when the DS4800 reader is connected by means of the CBX100/500:

CBX100/500 Terminal Block Connectors			
Input Power			
Vdc	Power Supply Input Voltage +		
GND	Power Supply Input Voltage -		
Earth	Protection Earth Ground		
Inputs			
+V	Power Source – External Trigger		
I1A	External Trigger A (polarity insensitive)		
I1B	External Trigger B (polarity insensitive)		
-V	Power Reference – External Trigger		
+V	Power Source – Inputs		
I2A	Input 2 A (polarity insensitive)		
I2B	Input 2 B (polarity insensitive)		
-V	Power Reference – Inputs		
Outputs			
+V	Power Source - Outputs		
-V	Power Reference - Outputs		
O1+	Output 1 +		
O1-	Output 1 -		
O2+	Output 2 +		
O2-	Output 2 -		
Auxiliary Interface			
TX	Auxiliary Interface TX		
RX	Auxiliary Interface RX		
SGND	Auxiliary Interface Reference		
ID-NET™			
REF	Network Reference		
ID+	ID-NET™ network +		
ID-	ID-NET™ network -		
Shield	Network Cable Shield		
Main Interface			
	RS232	RS485 Full-Duplex	RS485 Half-Duplex
	TX	TX+	RTX+
	RX	*RX+	
	RTS	TX-	RTX-
	CTS	*RX-	
	SGND	SGND	SGND

* Do not leave floating, see par. 4.2.2 for connection details.

 **NOTE** To avoid electromagnetic interference when the scanner is connected to a CBX connection box, verify the jumper positions in the CBX as indicated in its Installation Manual.

4.1 POWER SUPPLY

Power can be supplied to the scanner through the CBX100/500 spring clamp terminal pins as shown in Figure 25:

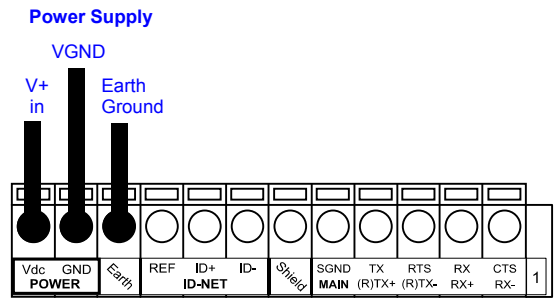



Figure 25 - Power Supply Connections

The power must be between 10 and 30 Vdc only.

It is recommended to connect the device CHASSIS to earth ground (Earth) by setting the appropriate jumper in the CBX connection box. See the CBX Installation Manual for details.

4.2 MAIN SERIAL INTERFACE

 **CAUTION** Do not connect to the Main Interface spring clamp terminals if using Host Interface Modules (Fieldbus) with the CBX500.

The signals relative to the following serial interface types are available on the CBX spring clamp terminal blocks.

If the interface type is not compatible with the current communication handshaking, then the system forces the handshake to **none**.

The main interface type and the relative parameters (baud rate, data bits, etc.) can be set using the Genius™ utility program or the Genius™ based Host Mode Programming procedure.

Details regarding the connections and use of the interfaces are given in the next paragraphs.

4.2.1 RS232 Interface

The serial interface is used in this case for point-to-point connections; it handles communication with the host computer and allows both transmission of code data and the programming of the scanner. This is the default setting.

The following pins are used for RS232 interface connection:

CBX100/500	Function
TX	Transmit Data
RX	Receive Data
RTS	Request To Send
CTS	Clear To Send
SGND	Signal Ground

It is always advisable to use shielded cables. The overall maximum cable length must be less than 15 m (49.2 ft).

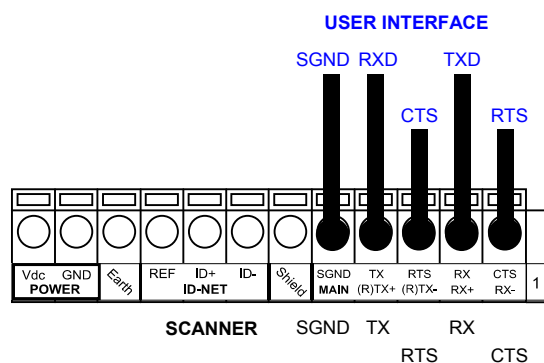

Figure 26 – RS232 Main Interface Connections Using Hardware Handshaking

The RTS and CTS signals control data transmission and synchronize the connected devices.

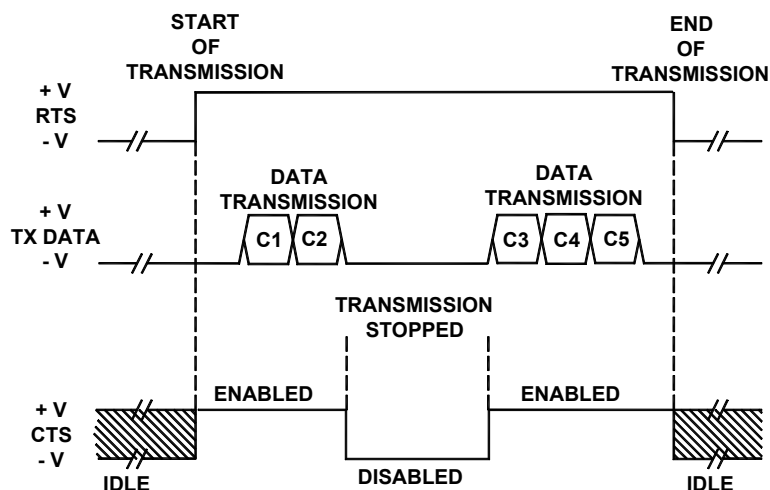

Figure 27 - RS232 Control Signals

If the RTS/CTS handshaking protocol is enabled, the DS4800 activates the RTS output to indicate a message is to be transmitted. The receiving unit activates the CTS input to enable the transmission.

4.2.2 RS485 Full-Duplex Interface

The RS485 full-duplex (5 wires + shield) interface is used for non-pollled communication protocols in point-to-point connections over longer distances (max 1200 m / 3940 ft) than those acceptable for RS232 communications or in electrically noisy environments.

The CBX pinout follows:

CBX100/500	Function
TX+	RS485 Transmit Data +
RX+	RS485 Receive Data +
TX-	RS485 Transmit Data -
RX-	RS485 Receive Data -
SGND	Signal Ground

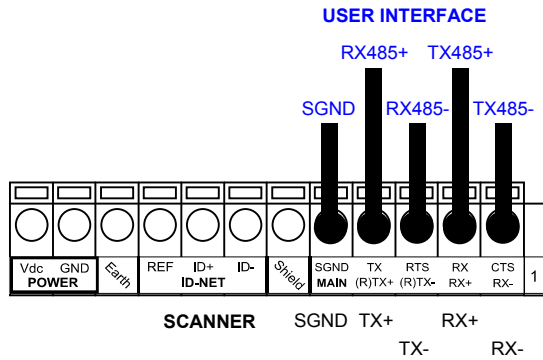

Figure 28 - RS485 Full-duplex Connections

NOTE For applications that do not use RX485 signals, do not leave these lines floating but connect them to SGND as shown below.

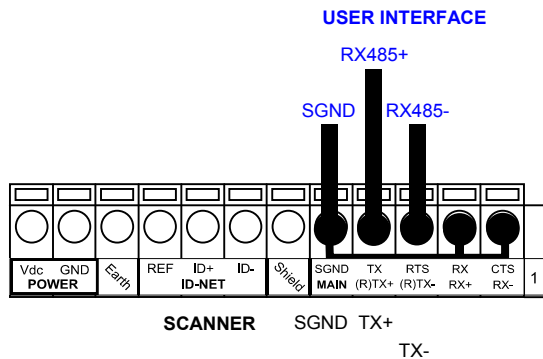

Figure 29 - RS485 Full-duplex Connections using Only TX Signals

4.2.3 RS485 Half-Duplex Interface



NOTE

This interface is provided for backward compatibility. We recommend using the more efficient ID-NET™ network for Master/Slave or Multiplexer layouts.

The RS485 half-duplex (3 wires + shield) interface is used for polled communication protocols.

It can be used for Multidrop connections with a Datalogic Multiplexer, (see par. 6.5) exploiting a proprietary protocol based on polled mode called MUX32 protocol, where a master device polls slave devices to collect data.

CBX100/500	Function
RTX+	RS485 Receive/Transmit Data +
RTX-	RS485 Receive/Transmit Data -
SGND	Signal Ground

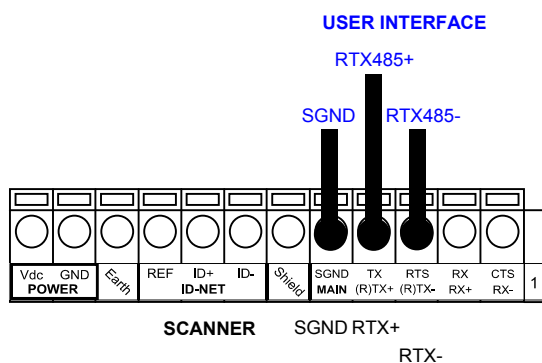

Figure 30 - RS485 Half-duplex Connections

This interface is forced by software when the protocol selected is MUX32 protocol.

In a Multiplexer layout, the Multidrop address must also be set via serial channel by the Genius™ utility or by the Host Programming Mode.

Figure 31 shows a multidrop configuration with DS4800 scanners connected to a Multiplexer.



CAUTION

This is an example of multidrop wiring. Consult the multiplexer manual for complete wiring instructions.

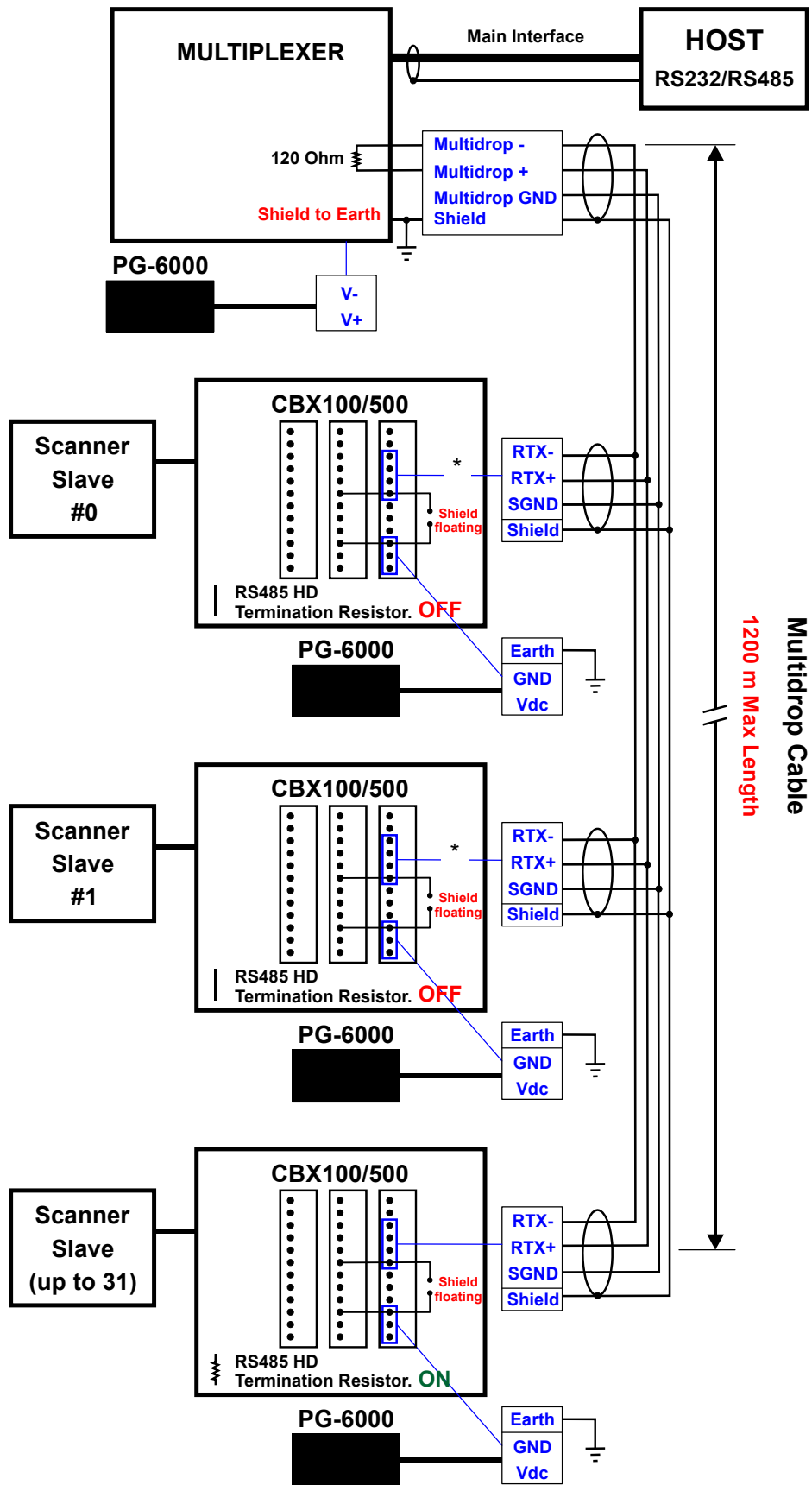

Figure 31 – DS4800 Multidrop Connection to a Multiplexer

* When using CBX500, the **Main** interface multidrop network signals: **Shield**, **SGND**, **RTX+** and **RTX-** are repeated on terminal connector row 4 to facilitate system cabling.

4.3 ID-NET™ INTERFACE

CBX100/500	Function
Shield	Network Cable Shield
ID+	ID-NET™ network +
ID-	ID-NET™ network -
REF	Network Reference

4.3.1 ID-NET™ Cables

The following instructions are referred to Figure 33, Figure 34 and Figure 35.

- The general cable type specifications are: CAT5 twisted pair + additional CAT5 twisted pair, shielded cable AWG 24 (or AWG 22) stranded flexible.

We recommend using DeviceNet cables (drop or trunk type) to the following reference standards:

AN50325 – IEC 62026

UL STYLE 2502 80°C 30V

- Cable Shield MUST be connected to earth ground ONLY at the Master.
- NEVER use ID-NET™ cable shield as common reference.
- The ID-NET™ max cable length depends on the baudrate used, (see the Baudrate Table below).
- For Common Power Connections use only 2 wires (ID+ and ID-).
 - DC Voltage Power cable (Vdc – GND) should be handled as a signal cable (i.e. do not put it together with AC cable):
 - Wire dimensioning must be checked in order to avoid voltage drops greater than 0.8 Volts.
 - Cable should lie down as near as possible to the ID-NET™ cable (avoiding wide loops between them).
- Scanner's chassis may be connected to earth.
- Network inside the same building.

Baudrate Table				
Baud Rate	125 kbps	250 kbps	500 kbps	1Mbps
Cable Length	1200 m	900 m	700 m	*

* Application dependent, contact your Datalogic Automation representative for details.



NOTE

The default ID-NET™ baudrate is 500 kbps. Lower ID-NET™ baudrates allow longer cable lengths. The baudrate is software configurable by authorized Datalogic Automation personnel only.

4.3.2 ID-NET™ Response Time

The following figure shows the response time of the ID-NET™ network. This time is defined as the period between the Trigger activation and the beginning of data transmission to the Host.

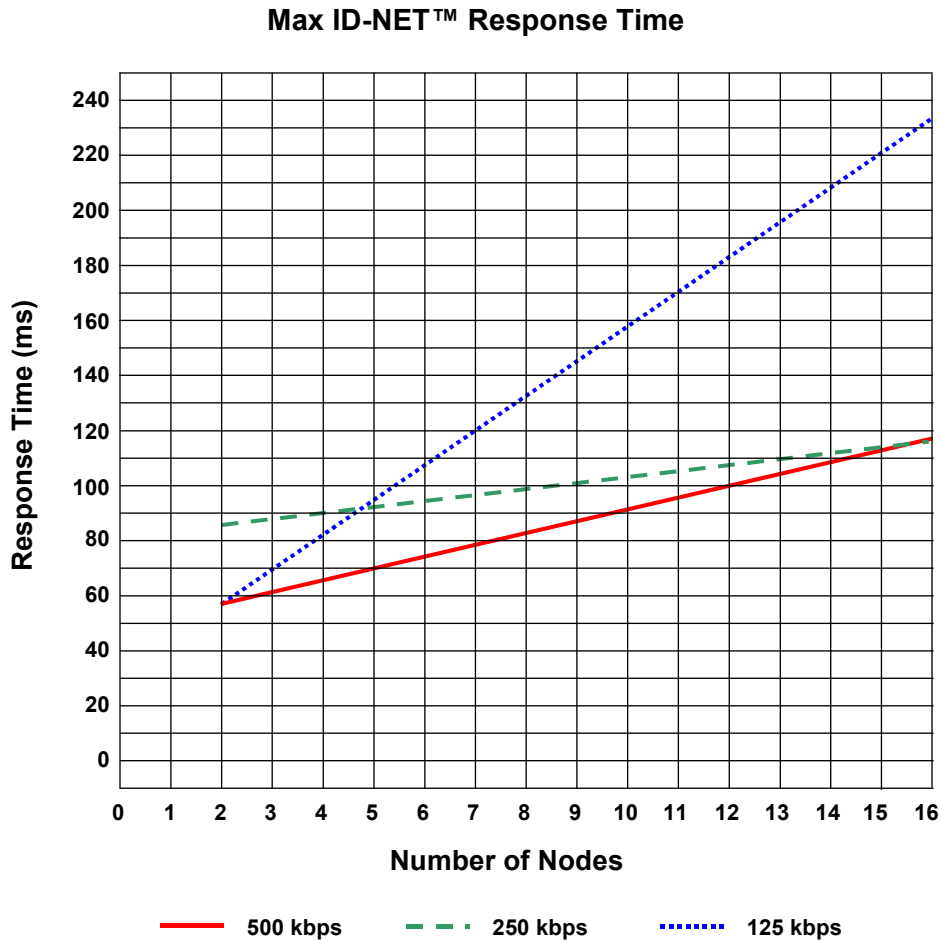

Figure 32 – ID-NET™ Response Time

CONDITIONS:

- ID-NET™ M/S Synchronized layout
- message length = 50 bytes per node

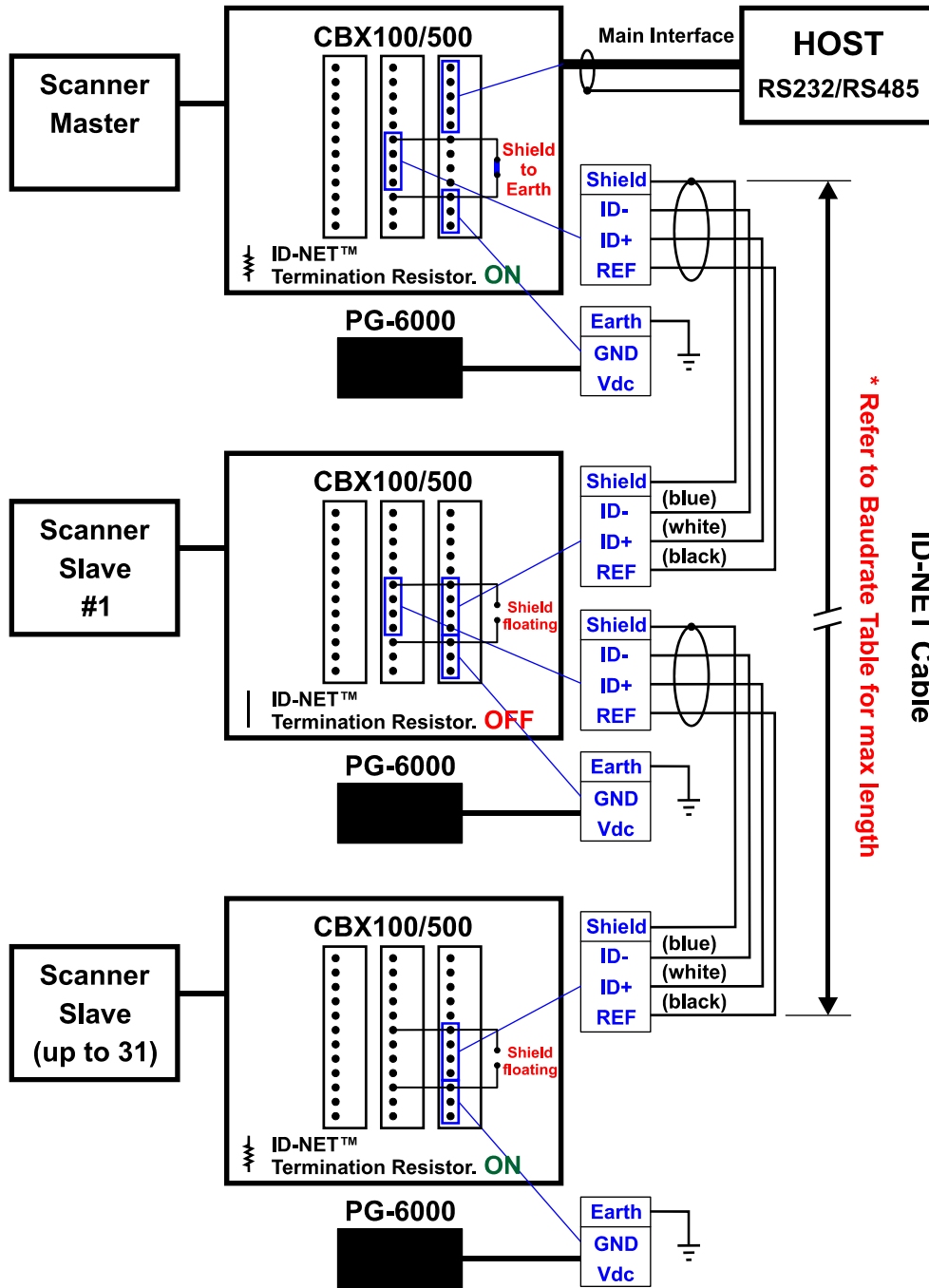

Figure 33 – ID-NET™ Network Connections with isolated power blocks

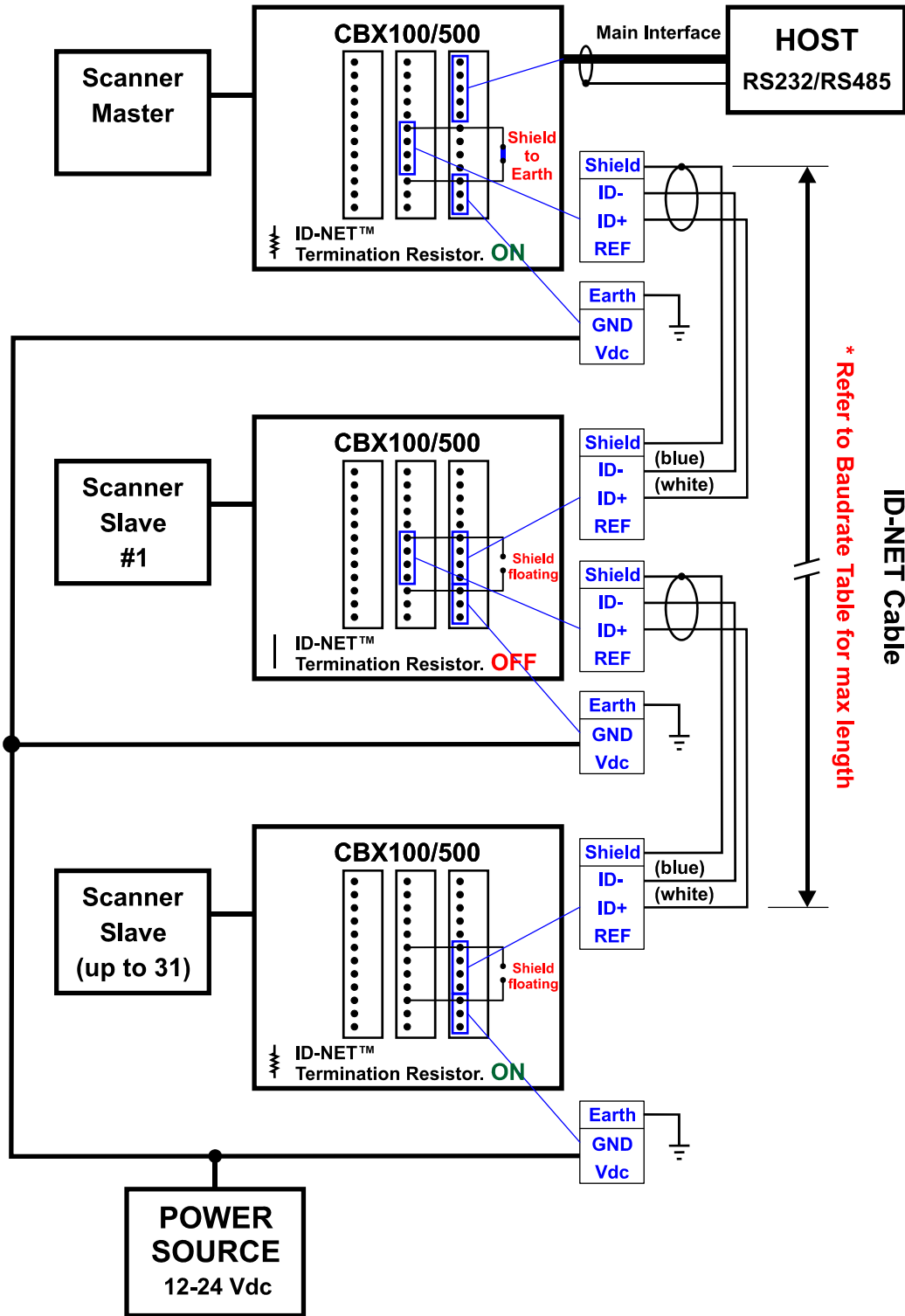

Figure 34 - ID-NET™ Network Connections with Common Power Branch Network

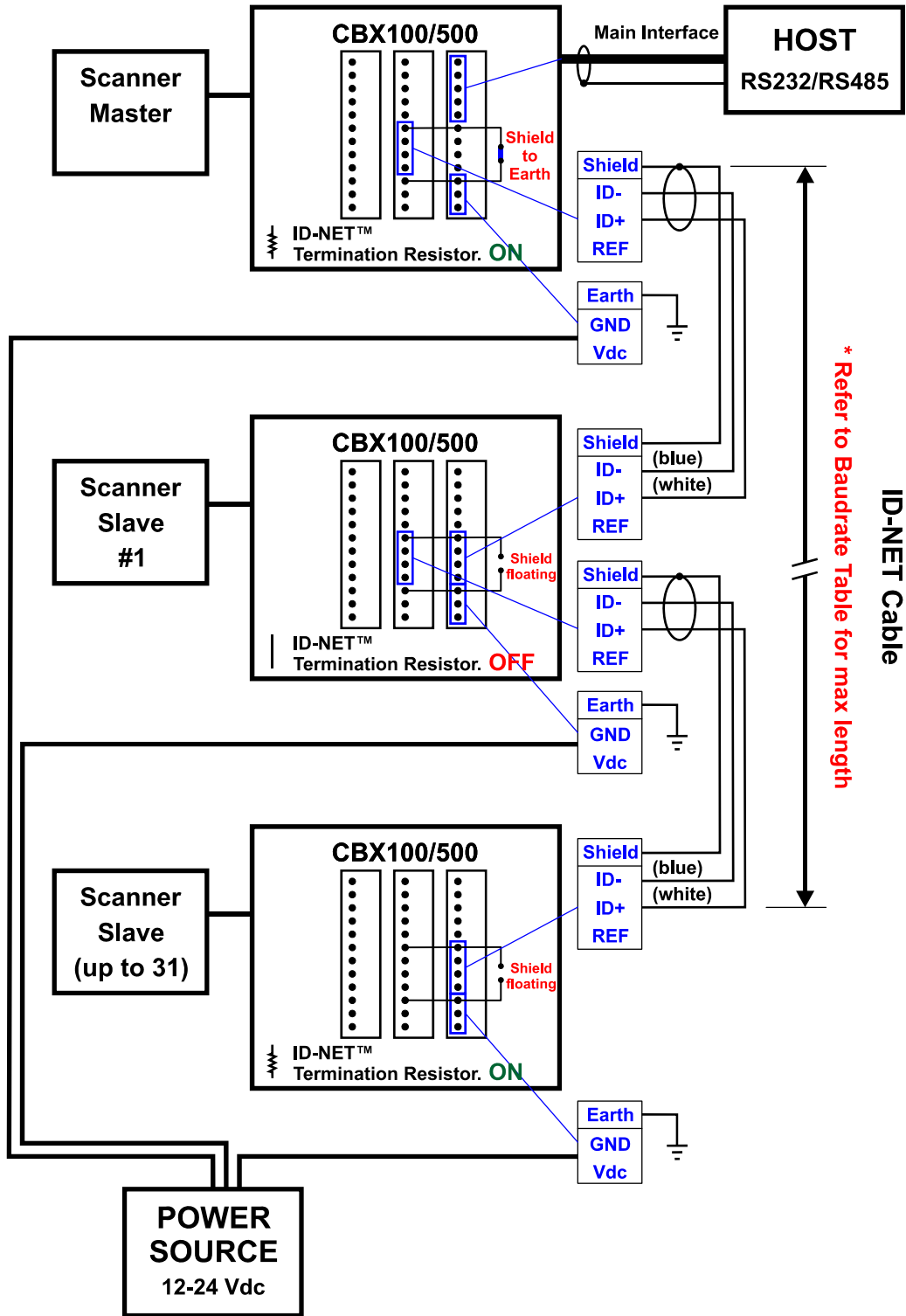

Figure 35 – ID-NET™ Network Connections with Common Power Star Network

4.3.3 ID-NET™ Network Termination

The network must be properly terminated in the first and last scanner of the network. This is done by setting the ID-NET™ Termination Resistance Switch in the CBX100/500 to ON.

4.4 AUXILIARY RS232 INTERFACE

The auxiliary serial interface is used exclusively for RS232 point-to-point connections.

The parameters relative to the aux interface (baud rate, data bits, etc.) as well as particular communication modes such as LOCAL ECHO can be defined using the Genius™ utility program or Genius™ based Host Mode Programming installed from the CD-ROM.

The 9-pin female Auxiliary Interface connector inside the CBX is the preferred connector for device configuration or communication monitoring.

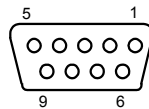

Figure 36 - 9-pin female connector

If permanent system wiring is required, the following pins are used to connect the RS232 auxiliary interface:

CBX100/500	Function
RX	Auxiliary Interface Receive Data
TX	Auxiliary Interface Transmit Data
SGND	Auxiliary Interface Reference

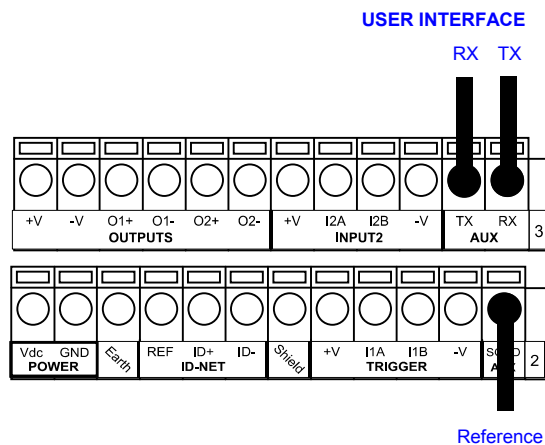

Figure 37 - RS232 Auxiliary Interface Connections

Do not connect the Aux Interface to the CBX spring clamp connectors and the 9-pin connector simultaneously.

NOTE

4.5 INPUTS

There are two optocoupled polarity insensitive inputs available on the scanner: Input 1 (External Trigger) and Input 2, a generic input:

The electrical features of both inputs are:

Maximum voltage:	30 Vdc
Maximum current:	12 mA (scanner) + 12 mA (CBX)

An anti-disturbance filter is implemented in software on both inputs so that the minimum pulse duration is \cong 5 milliseconds. This value can be increased through the software parameter Debounce Filter, see the "2K/4K Family Software Configuration Parameter Guide" Help file".

CBX100/500	Function
+V	Power Source - External Trigger
I1A	External Trigger A (polarity insensitive)
I1B	External Trigger B (polarity insensitive)
-V	Power Reference - External Trigger

The External Trigger input is used in the On-Line operating Mode and tells the scanner to scan for a code. The active state of this input is selected in software. Refer to the Genius™ Help On Line.

The yellow Trigger LED ([Figure A, 3](#)) is on when the active state of the External Trigger corresponds to ON.

This input is optocoupled and can be driven by both an NPN and PNP type command. The connections are indicated in the following diagrams:

EXTERNAL TRIGGER INPUT CONNECTIONS USING DS4800 POWER

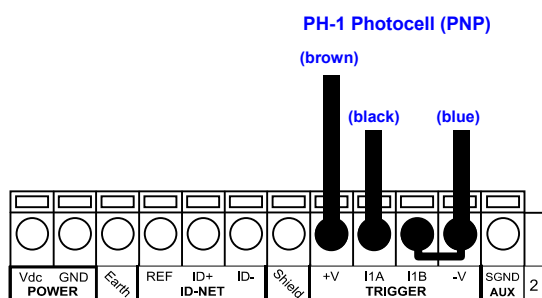

Figure 38 – PH-1 Photocell (PNP) External Trigger Using DS4800 Power

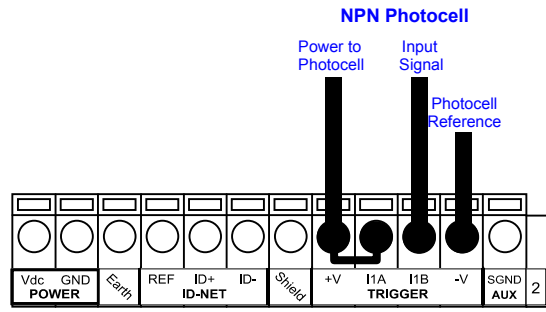

Figure 39 - NPN External Trigger Using DS4800 Power

EXTERNAL TRIGGER INPUT CONNECTIONS USING EXTERNAL POWER

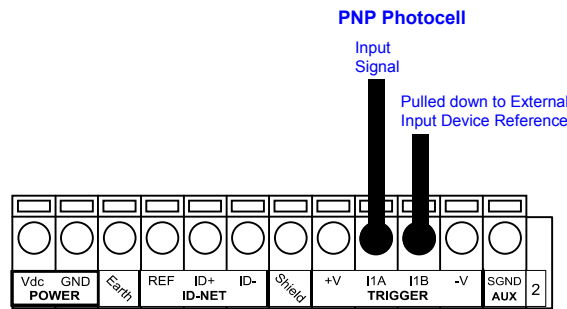

Figure 40 - PNP External Trigger Using External Power

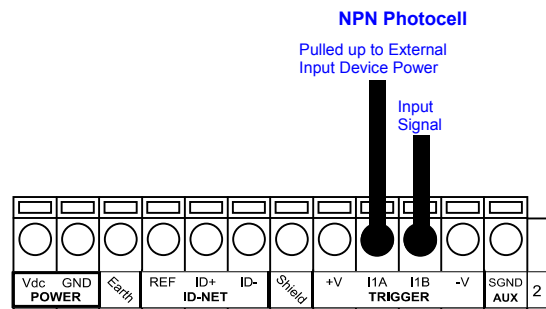
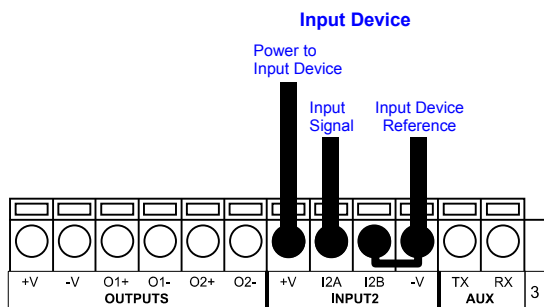

Figure 41 - NPN External Trigger Using External Power

CBX100/500	Function
+V	Power Source - Inputs
I2A	Input 2 A (polarity insensitive)
I2B	Input 2 B (polarity insensitive)
-V	Power Reference - Inputs

INPUT 2 CONNECTIONS USING DS4800 POWER



PNP Input 2 Using DS4800 Power

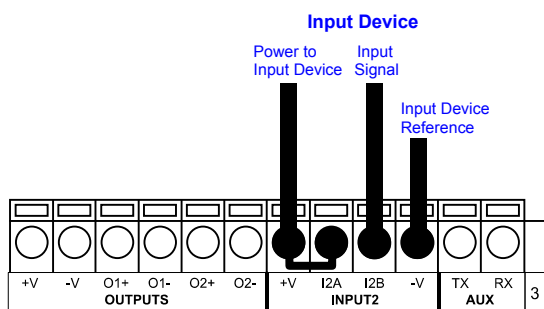

NPN Input 2 Using DS4800 Power

INPUT 2 CONNECTIONS USING EXTERNAL POWER

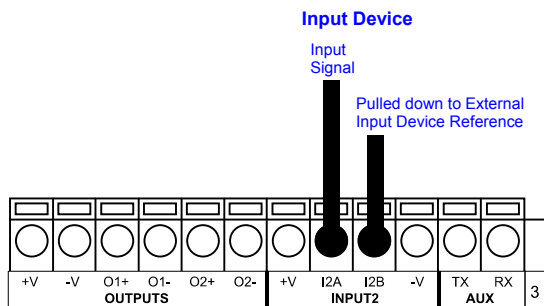

Figure 42 - PNP Input 2 Using External Power

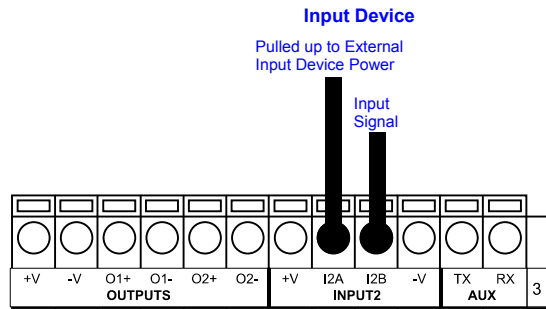

Figure 43 - NPN Input 2 Using External Power

4.5.1 Code Verifier

If the DS4800 is used as a Code Verifier, the verifier code can be configured in software through the Genius™ configuration program. However it is also possible to use one of the inputs to trigger when the scanner should store a code read as the verifier code.

The Code Verifier parameter must be enabled, and the configuration parameters to allow correct Code Type reading must be saved to the scanner in order to read the verifier code.

When the selected input is activated, the next read code will be stored as the verifier code in the scanner's non-volatile (Flash) memory.

For more details see the Verifier Parameters in the "2K/4K Family Software Configuration Parameter Guide" Help file".

4.6 OUTPUTS

Two general purpose outputs are available.

CBX100/500	Function
+V	Power Source - Outputs
O1+	Output 1 +
O1-	Output 1 -
O2+	Output 2 +
O2-	Output 2 -
-V	Power Reference Outputs

The meaning of the two outputs Output 1 and Output 2 can be defined by the user (No Read, Right, Wrong, etc.). Refer to the Genius™ Help On Line.

By default, Output 1 is associated with the No Read event, which activates when the code signaled by the external trigger is not decoded, and Output 2 is associated with the Complete Read event, which activates when all the selected codes are correctly decoded.

The output signals are fully programmable being determined by the configured Activation/Deactivation events, Deactivation Timeout or a combination of the two.

OUTPUT CONNECTIONS USING DS4800 POWER

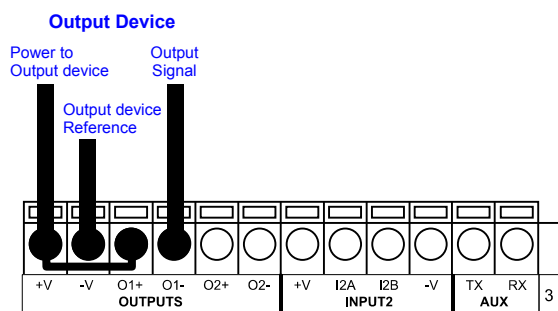

Figure 44 - Open Emitter Output Using DS4800 Power

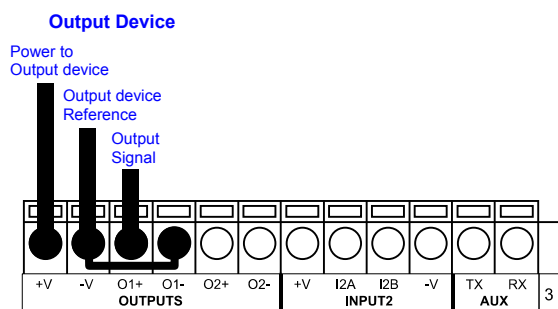

Figure 45 - Open Collector Output Using DS4800 Power

OUTPUT CONNECTIONS USING EXTERNAL POWER

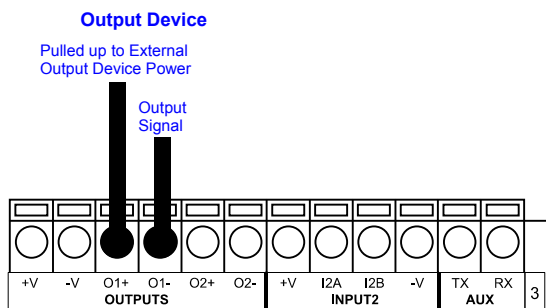

Figure 46 - Open Emitter Output Using External Power

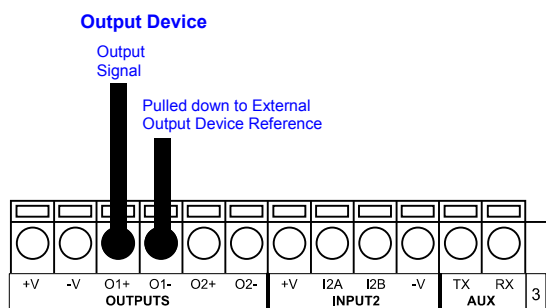

Figure 47 - Open Collector Output Using External Power

$V_{CE\ max} = 30\ Vdc$

$I_{max} = 40\ mA\ continuous; 130\ mA\ pulsed$

4.7 USER INTERFACE - HOST

The following table contains the pinout for standard RS232 PC Host interface. For other user interface types please refer to their own manual.

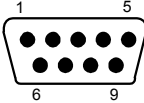
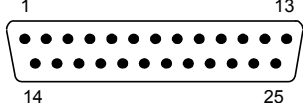
RS232 PC-side connections			
 <p>9-pin male connector</p>		 <p>25-pin male connector</p>	
Pin	Name	Pin	Name
2	RX	3	RX
3	TX	2	TX
5	GND	7	GND
7	RTS	4	RTS
8	CTS	5	CTS

5 25-PIN CABLE ELECTRICAL CONNECTIONS

All DS4800 models are equipped with a cable terminated by a 25-pin male D-sub connector for connection to the power supply and input/output signals. The details of the connector pins are indicated in the following table.

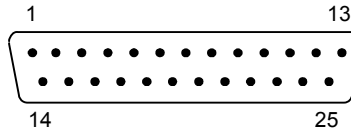

Figure 48 - 25-pin Male D-sub Connector

25-pin D-sub male connector pinout				
Pin	Name	Function		
13, 9	Vdc	Power supply input voltage +		
25, 7	GND	Power supply input voltage -		
1	CHASSIS	Cable shield connected to chassis		
18	I1A	External Trigger A (polarity insensitive)		
19	I1B	External Trigger B (polarity insensitive)		
6	I2A	Input 2 A (polarity insensitive)		
10	I2B	Input 2 B (polarity insensitive)		
8	O1+	Output 1 +		
22	O1-	Output 1 -		
11	O2+	Output 2 +		
12	O2-	Output 2 -		
20	RX	Auxiliary Interface RX		
21	TX	Auxiliary Interface TX		
23	ID+	ID-NET™ network +		
24	ID-	ID-NET™ network -		
14, 15, 16, 17	NC	Not Connected		
Pin	Name	RS232	RS485 Full-Duplex	RS485 Half-Duplex
2	MAIN INTERFACE (SW SELECTABLE)	TX	TX+	RTX+
3		RX	*RX+	RTX-
4		RTS	TX-	
5		CTS	*RX-	

* Do not leave floating, see par. 5.2.2 for connection details.

5.1 POWER SUPPLY

Power can be supplied to the scanner through the pins provided on the 25-pin connector used for communication with the host (Figure 49):

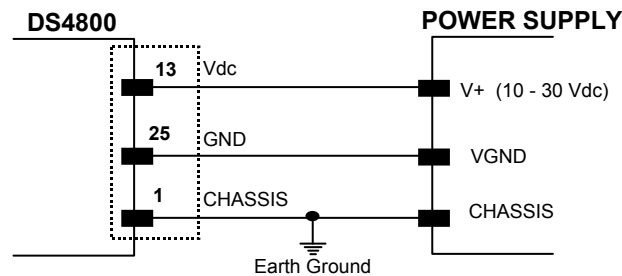

Figure 49 - Power Supply Connections

The power must be between 10 and 30 Vdc only.

It is recommended to connect pin 1 (CHASSIS) to a common earth ground.

5.2 MAIN SERIAL INTERFACE

The signals relative to the following serial interface types are available on the input/output connector of DS4800.

If the interface type is not compatible with the current communication handshaking, then the system forces the handshake to **none**.

The main interface type and the relative parameters (baud rate, data bits, etc.) can be set using the Genius™ utility program or the Genius™ based Host Mode Programming procedure.

Details regarding the connections and use of the interfaces are given in the next paragraphs.

5.2.1 RS232 Interface

The serial interface is used in this case for point-to-point connections; it handles communication with the host computer and allows both transmission of code data and the programming of the scanner. This is the default setting.

The following pins are used for RS232 interface connection:

25-pin	Name	Function
2	TX	Transmit Data
3	RX	Receive Data
4	RTS	Request To Send
5	CTS	Clear To Send
7	GND	Ground

It is always advisable to use shielded cables. The overall maximum cable length must be less than 15 m (49.2 ft).

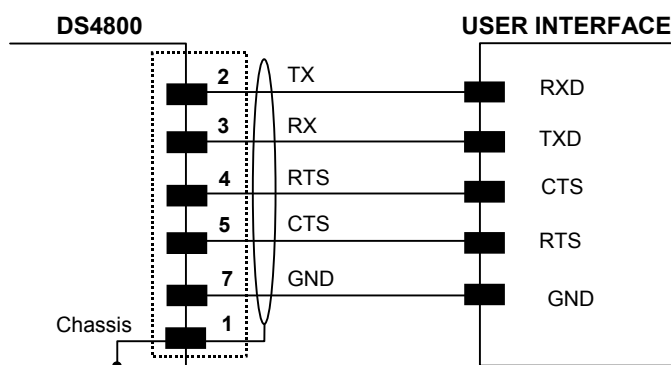

Figure 50 – RS232 Main Interface Connections Using Hardware Handshaking

The RTS and CTS signals control data transmission and synchronize the connected devices.

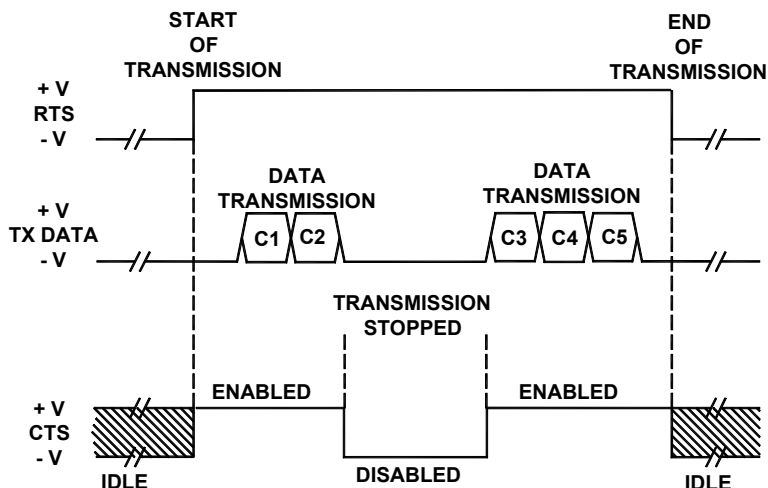

Figure 51 - RS232 Control Signals

If the RTS/CTS handshaking protocol is enabled, the DS4800 activates the RTS output to indicate a message is to be transmitted. The receiving unit activates the CTS input to enable the transmission.

5.2.2 RS485 Full-Duplex Interface

The RS485 full-duplex (5 wires + shield) interface is used for non-pollled communication protocols in point-to-point connections over longer distances (max 1200 m / 3940 ft) than those acceptable for RS232 communications or in electrically noisy environments.

The connector pinout follows:

25-pin	Name	Function
2	TX+	RS485 Transmit Data +
3	RX+	RS485 Receive Data +
4	TX-	RS485 Transmit Data -
5	RX-	RS485 Receive Data -
7	GND	Ground

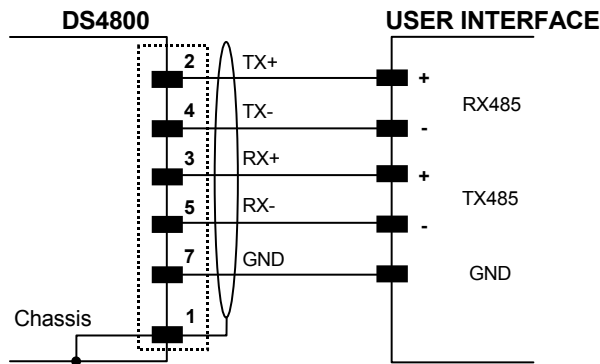



Figure 52 - RS485 Full-duplex Connections

 **NOTE** For applications that do not use RX signals, do not leave these lines floating but connect them to GND as shown below.

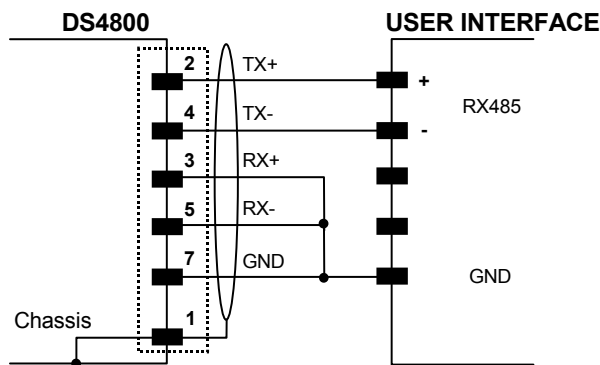

Figure 53 - RS485 Full-duplex Connections using Only TX Signals

5.2.3 RS485 Half-Duplex Interface



NOTE

This interface is provided for backward compatibility. We recommend using the more efficient ID-NET™ network for Master/Slave or Multiplexer layouts.

The RS485 half-duplex (3 wires + shield) interface is used for polled communication protocols.

It can be used for Multidrop connections with a Datalogic Multiplexer, (see par. 6.5) exploiting a proprietary protocol based on polled mode called MUX32 protocol, where a master device polls slave devices to collect data.

The connector pinout follows:

25-pin	Name	Function
2	RTX+	RS485 Receive/Transmit Data +
4	RTX-	RS485 Receive/Transmit Data -
7	GND	Ground

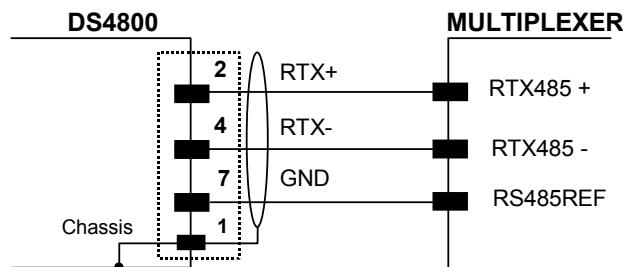

Figure 54 - RS485 Half-duplex Connections

This interface is forced by software when the protocol selected is MUX32 protocol.

In a Multiplexer layout, the Multidrop address must also be set via serial channel by the Genius™ utility or by the Host Programming Mode.

Figure 55 shows a multidrop configuration with DS4800 scanners connected to a Multiplexer.



CAUTION

This is an example of multidrop wiring. Consult the multiplexer manual for complete wiring instructions.

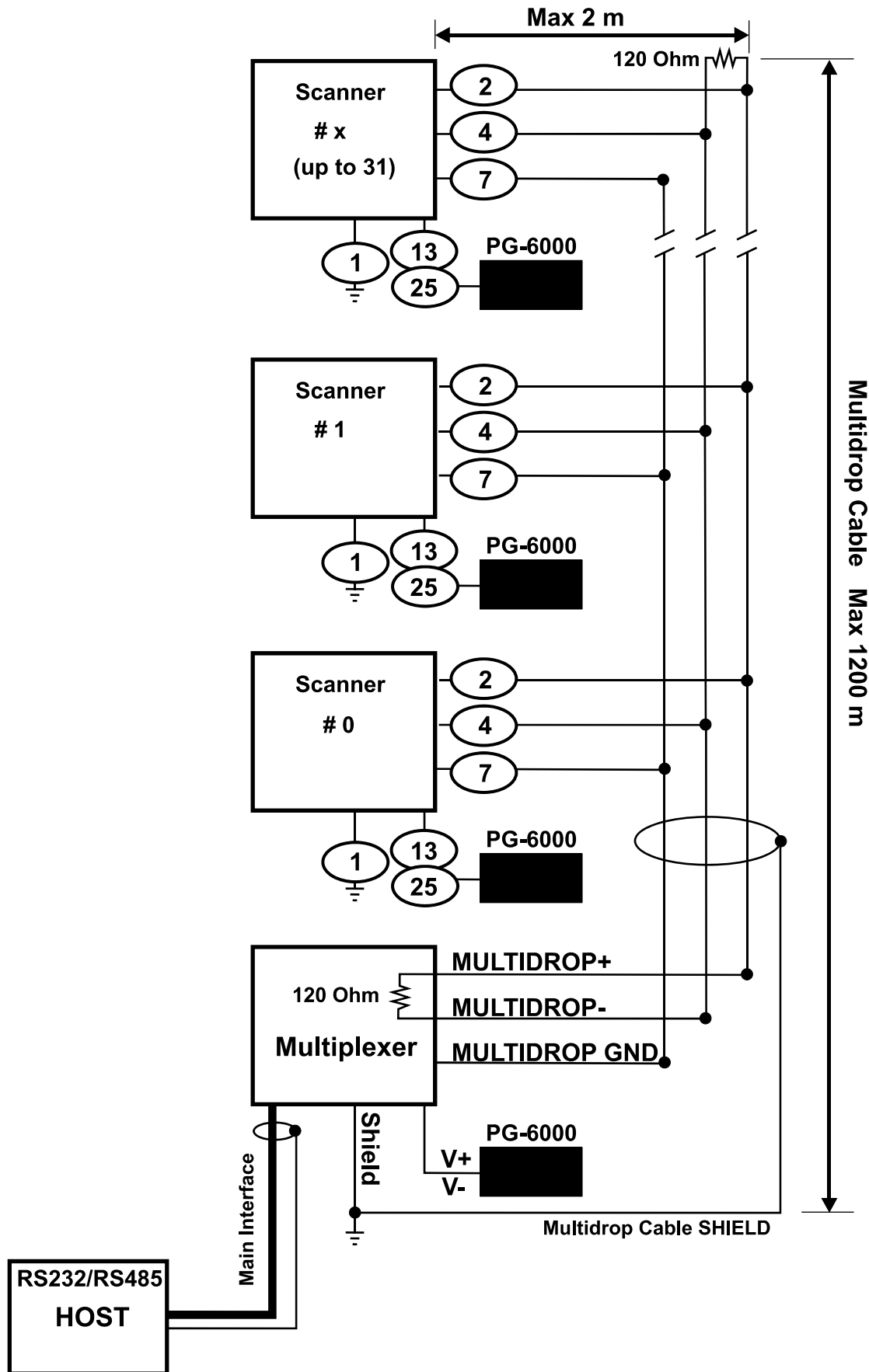

Figure 55 - DS4800 Multidrop Connection to a Multiplexer

5.3 ID-NET™ INTERFACE

25-pin	Name	Function
23	ID+	ID-NET™ network +
24	ID-	ID-NET™ network -
7	GND	Ground

5.3.1 ID-NET™ Cables

The following instructions are referred to Figure 57, Figure 58 and Figure 59.

- The general cable type specifications are: CAT5 twisted pair + additional CAT5 twisted pair, shielded cable AWG 24 (or AWG 22) stranded flexible.

We recommend using DeviceNet cables (drop or trunk type) to the following reference standards:

AN50325 – IEC 62026

UL STYLE 2502 80°C 30V

- Cable Shield MUST be connected to earth ground ONLY at the Master.
- NEVER use ID-NET™ cable shield as common reference.
- The ID-NET™ max cable length depends on the baudrate used, (see the Baudrate Table below).
- For Common Power Connections use only 2 wires (23 and 24).
 - DC Voltage Power cable (Vdc – GND) should be handled as a signal cable (i.e. do not put it together with AC cable):
 - Wire dimensioning must be checked in order to avoid voltage drops greater than 0.8 Volts.
 - Cable should lie down as near as possible to the ID-NET™ cable (avoiding wide loops between them).
- Scanner's chassis may be connected to earth.
- Network inside the same building.

Baudrate Table				
Baud Rate	125 kbps	250 kbps	500 kbps	1Mbps
Cable Length	1200 m	900 m	700 m	*

* Application dependent, contact your Datalogic Automation representative for details.



NOTE

The default ID-NET™ baudrate is 500 kbps. Lower ID-NET™ baudrates allow longer cable lengths. The baudrate is software configurable by authorized Datalogic Automation personnel only.

5.3.2 ID-NET™ Response Time

The following figure shows the response time of the ID-NET™ network. This time is defined as the period between the Trigger activation and the beginning of data transmission to the Host.

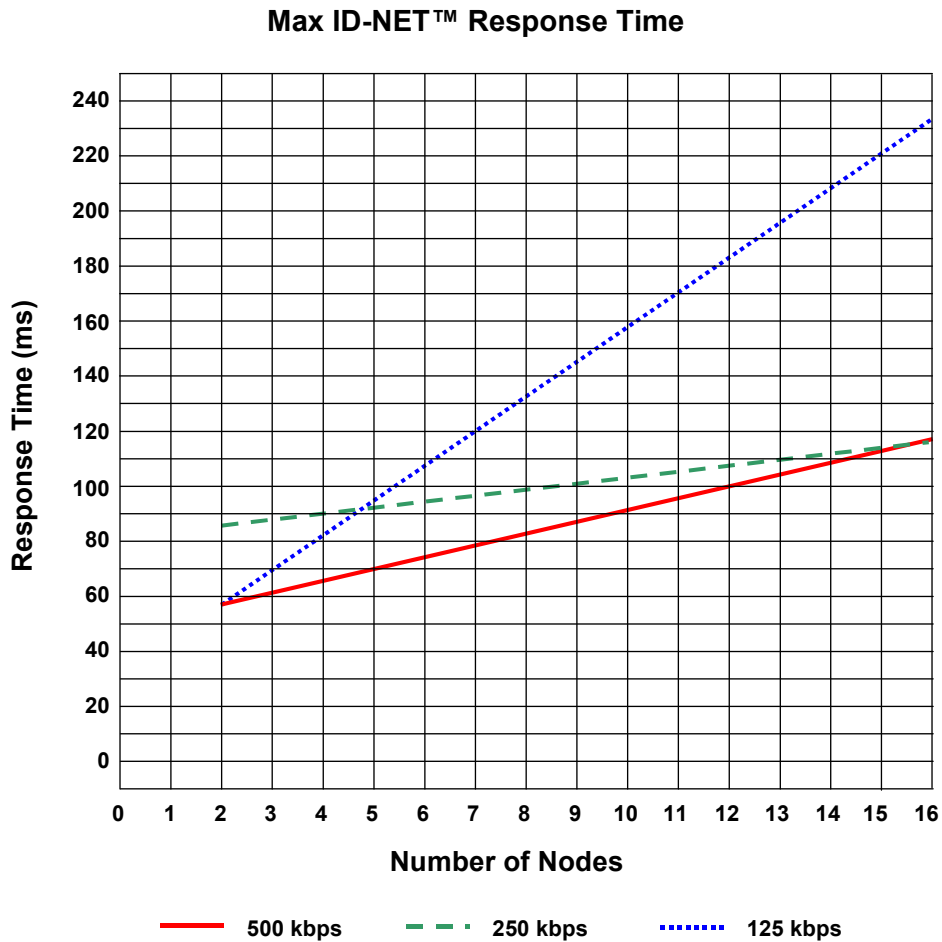

Figure 56 – ID-NET™ Response Time

CONDITIONS:

- ID-NET™ M/S Synchronized layout
- message length = 50 bytes per node

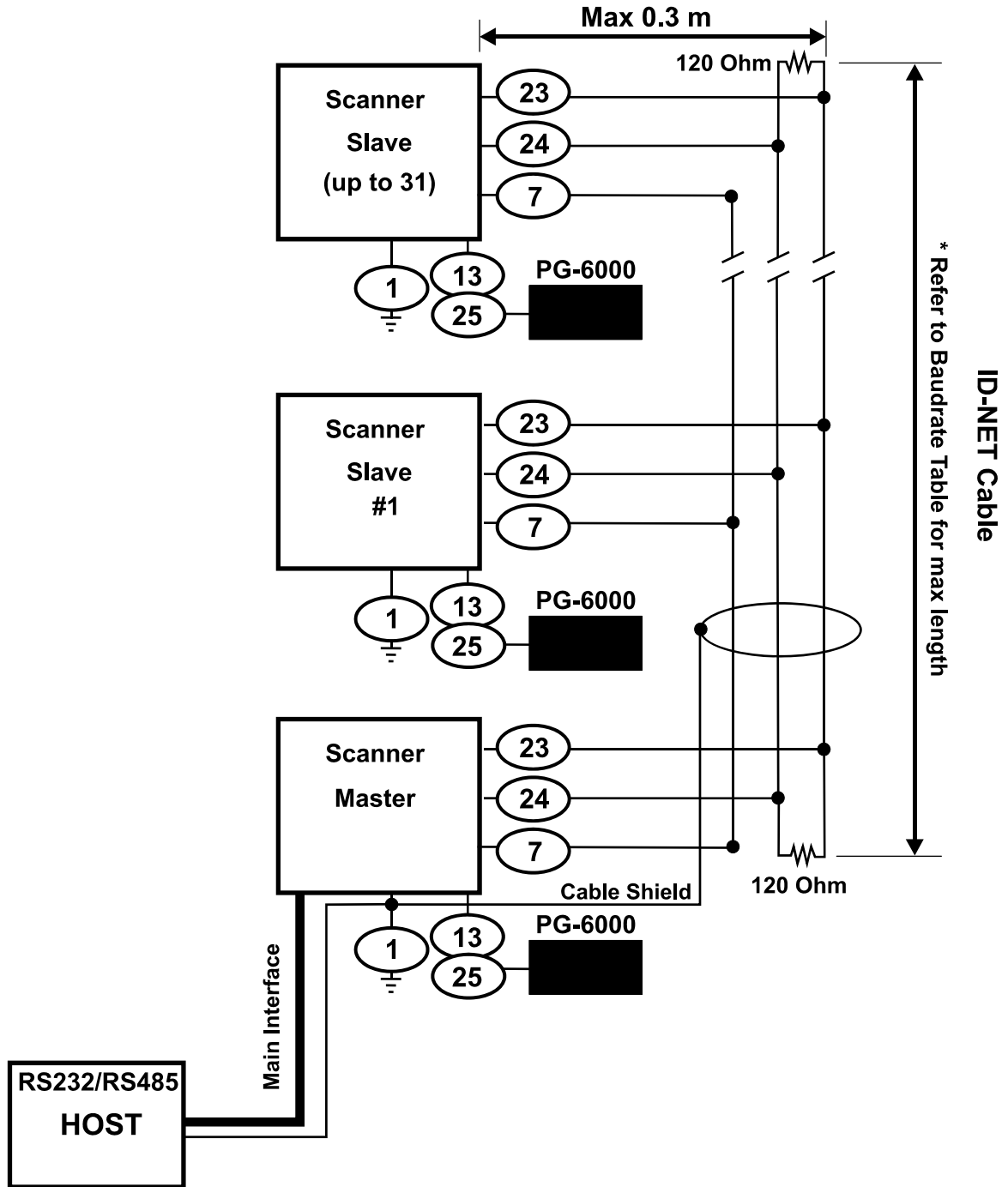

Figure 57 – ID-NET™ Network Connections with isolated power blocks

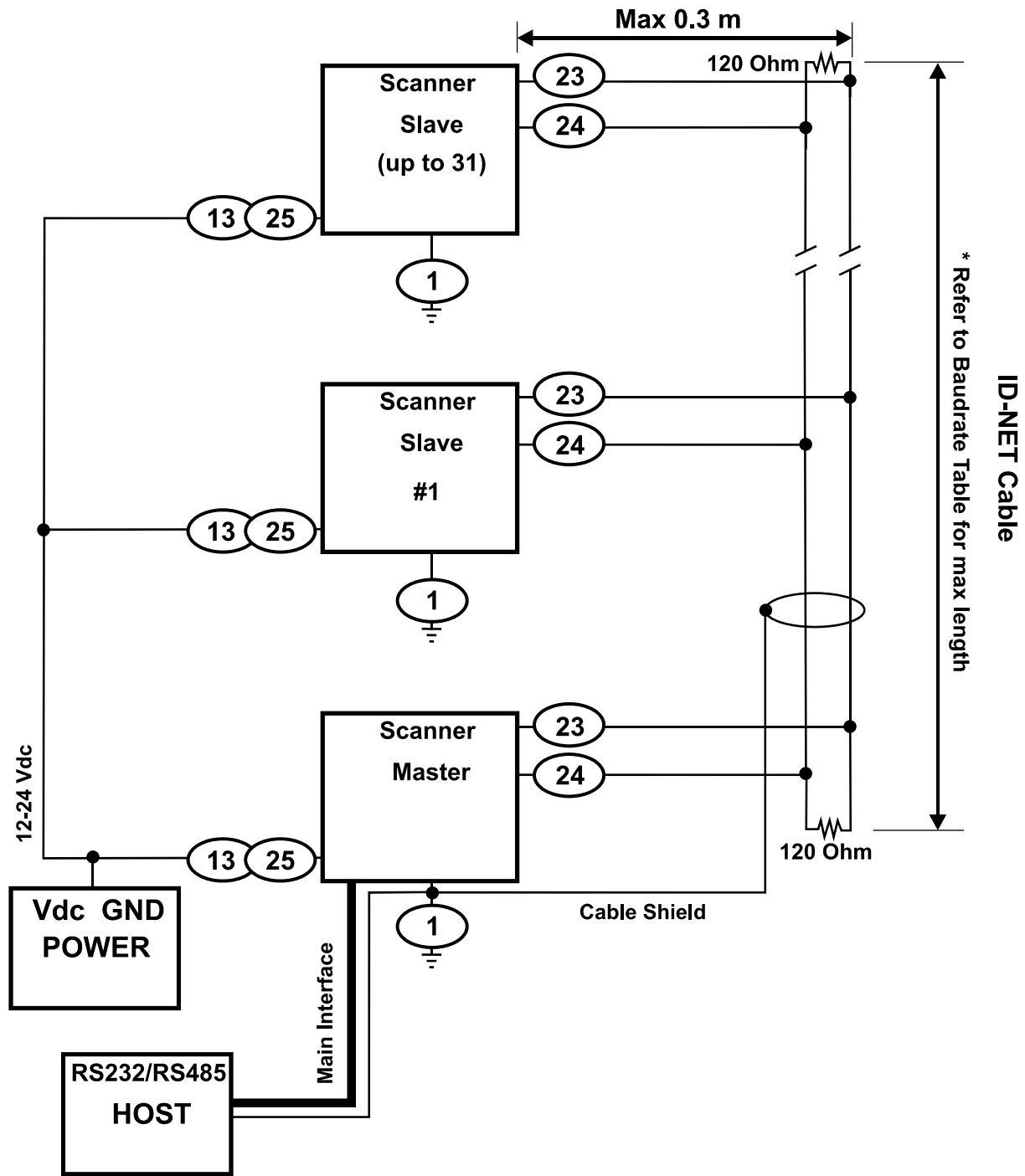

Figure 58 - ID-NET™ Network Connections with Common Power Branch Network

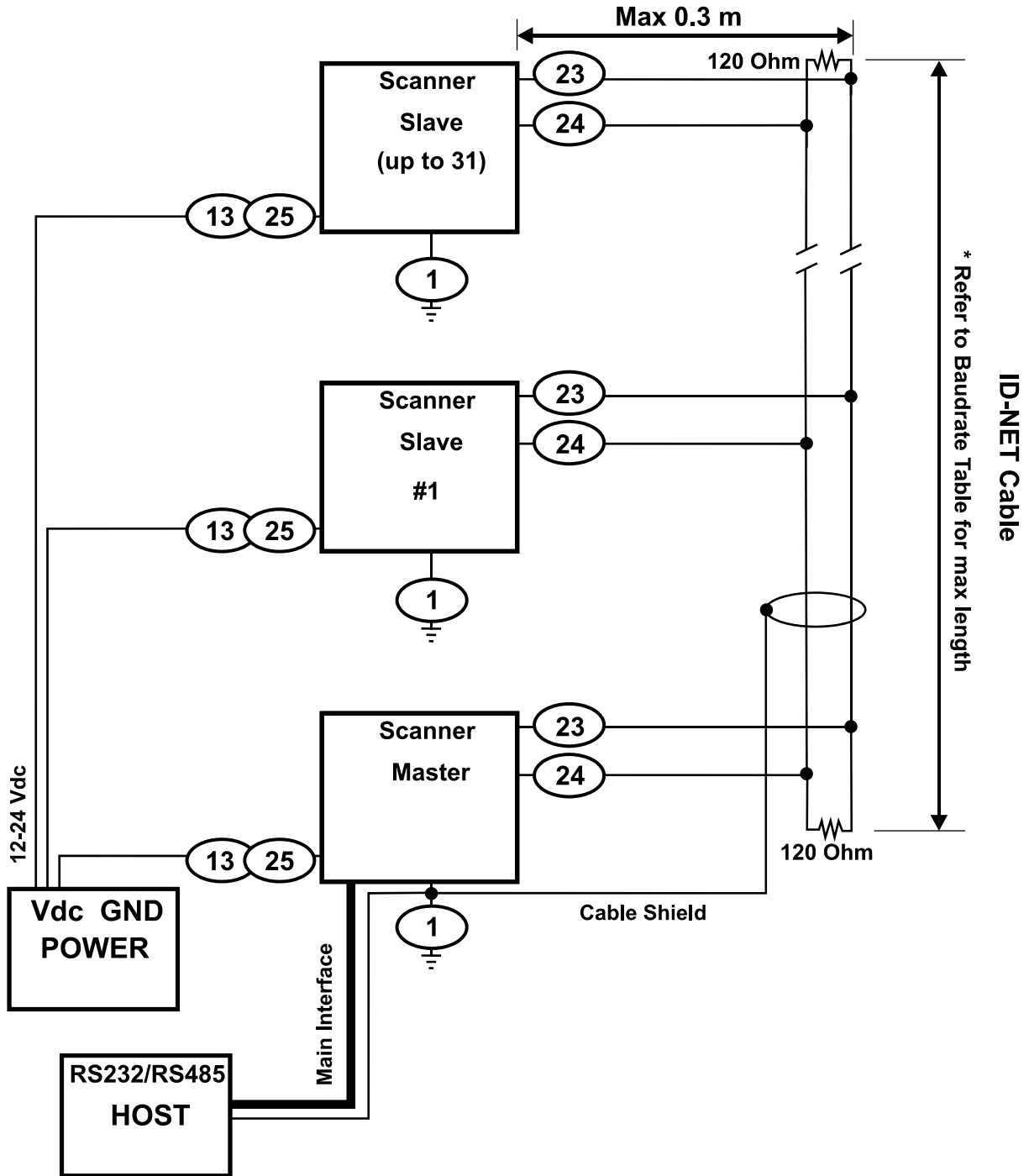

Figure 59 – ID-NET™ Network Connections with Common Power Star Network

5.3.3 ID-NET™ Network Termination

The network must be properly terminated by a 120 Ohm resistor at the first and last scanner of the network.

5.4 AUXILIARY RS232 INTERFACE

The auxiliary serial interface is used exclusively for RS232 point-to-point connections.

The parameters relative to the aux interface (baud rate, data bits, etc.) as well as particular communication modes such as LOCAL ECHO can be defined using the Genius™ utility program or Genius™ based Host Mode Programming installed from the CD-ROM.

The following pins of the 25-pin connector are used to connect the RS232 auxiliary interface:

Pin	Name	Function
20	RX	Receive Data
21	TX	Transmit Data
7	GND	Ground

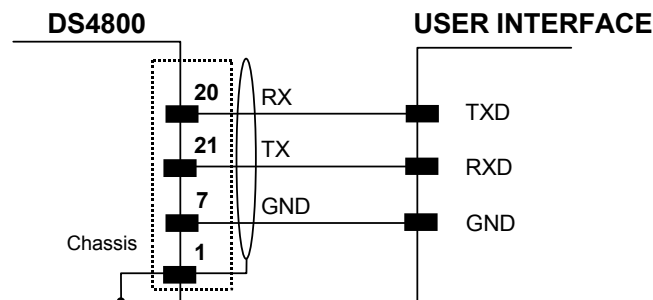

Figure 60 - RS232 Auxiliary Interface Connections

5.5 INPUTS

There are two optocoupled polarity insensitive inputs available on the scanner: Input 1 (External Trigger) and Input 2, a generic input:

The electrical features of both inputs are:

Maximum voltage:	30 Vdc
Maximum current:	12 mA

An anti-disturbance filter is implemented in software on both inputs so that the minimum pulse duration is \cong 5 milliseconds. This value can be increased through the software parameter Debounce Filter, see the "2K/4K Family Software Configuration Parameter Guide" Help file".

25-pin	Name	Function
9	Vdc	Power Source - External Trigger
18	I1A	External Trigger A (polarity insensitive)
19	I1B	External Trigger B (polarity insensitive)
7	GND	Power Reference - External Trigger

The External Trigger input is used in the On-Line operating Mode and tells the scanner to scan for a code. The active state of this input is selected in software. Refer to the Genius™ Help On Line.

The yellow Trigger LED ([Figure A](#), 3) is on when the active state of the External Trigger corresponds to ON.

This input is optocoupled and can be driven by both an NPN and PNP type command. The connections are indicated in the following diagrams:

EXTERNAL TRIGGER INPUT PNP PH-1

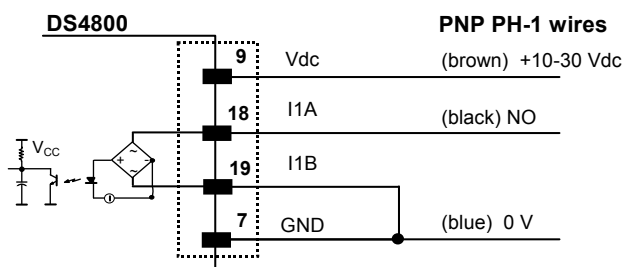

Figure 61 - PH-1 Photocell (PNP) External Trigger Using DS4800 Power

EXTERNAL TRIGGER INPUT CONNECTIONS USING DS4800 POWER

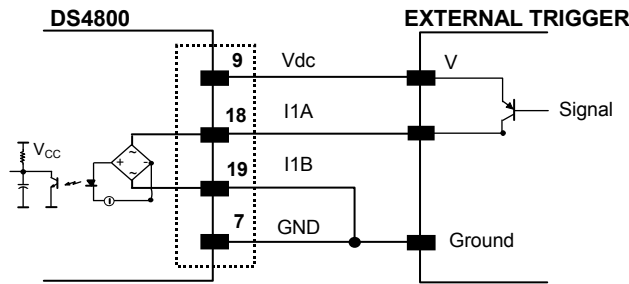

Figure 62 - PNP External Trigger Using DS4800 Power

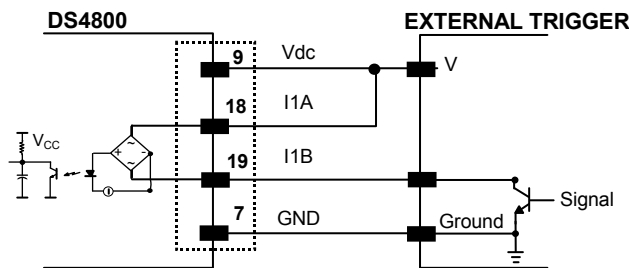

Figure 63 - NPN External Trigger using DS4800 power

EXTERNAL TRIGGER INPUT CONNECTIONS USING EXTERNAL POWER

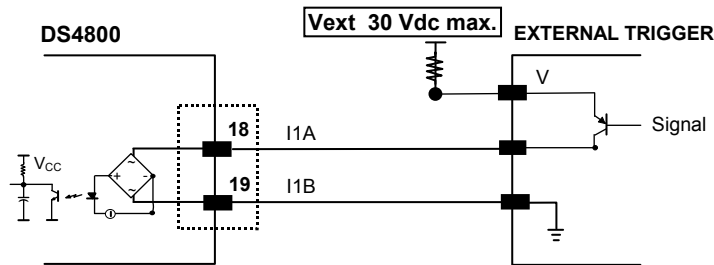

Figure 64 - PNP External Trigger Using External Power

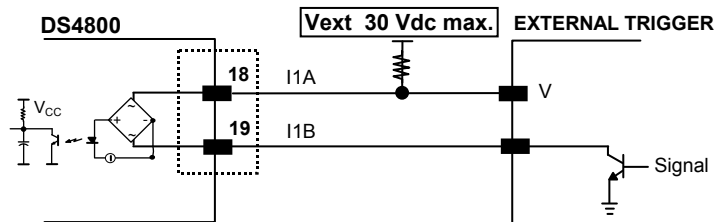

Figure 65 - NPN External Trigger Using External Power

25-pin	Name	Function
9	Vdc	Power Source Inputs
6	I2A	Input 2 A (polarity insensitive)
10	I2B	Input 2 B (polarity insensitive)
7	GND	Power Reference - Inputs

INPUT 2 CONNECTIONS USING DS4800 POWER

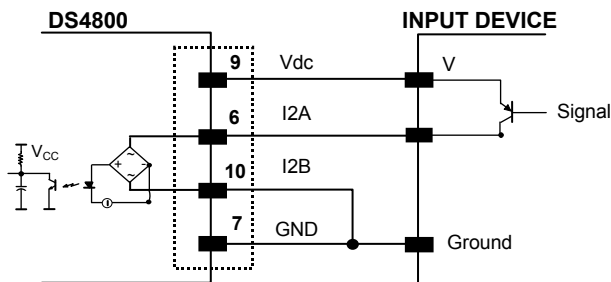

Figure 66 - PNP Input 2 Using DS4800 Power

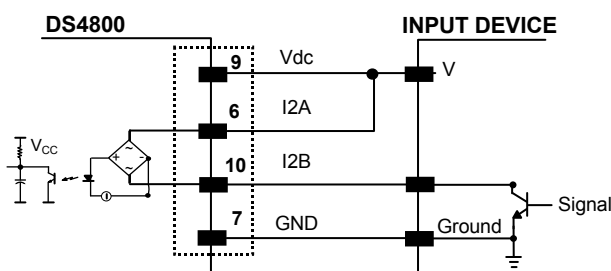

Figure 67 - NPN Input 2 Using DS4800 Power

INPUT 2 CONNECTIONS USING EXTERNAL POWER

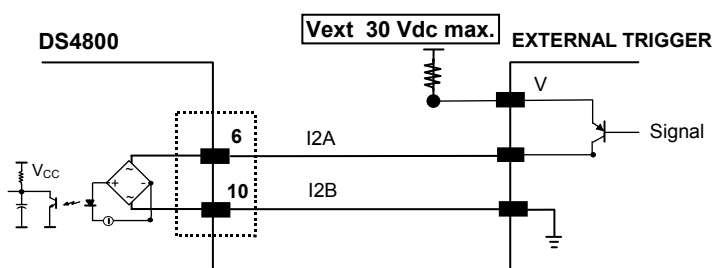

Figure 68 - PNP Input 2 Using External Power

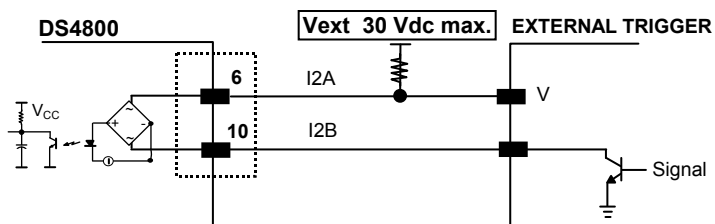

Figure 69 - NPN Input 2 Using External Power

5.5.1 Code Verifier

If the DS4800 is used as a Code Verifier, the verifier code can be configured in software through the Genius™ configuration program. However it is also possible to use one of the inputs to trigger when the scanner should store a code read as the verifier code.

The Code Verifier parameter must be enabled, and the configuration parameters to allow correct Code Type reading must be saved to the scanner in order to read the verifier code.

When the selected input is activated, the next read code will be stored as the verifier code in the scanner's non-volatile (Flash) memory.

For more details see the Verifier Parameters in the "2K/4K Family Software Configuration Parameter Guide" Help file".

5.6 OUTPUTS

Two general purpose outputs are available. The following pins are present on the 25-pin connector of the scanner:

25-pin	Name	Function
9	Vdc	Power Source - Outputs
8	O1+	Output 1 +
22	O1-	Output 1 -
11	O2+	Output 2 +
12	O2-	Output 2 -
7	GND	Power Reference - Outputs

The meaning of the two outputs Output 1 and Output 2 can be defined by the user (No Read, Right, Wrong, etc.). Refer to the Genius™ Help On Line.

By default, Output 1 is associated with the No Read event, which activates when the code signaled by the external trigger is not decoded, and Output 2 is associated with the Complete Read event, which activates when all the selected codes are correctly decoded.

The output signals are fully programmable being determined by the configured Activation/Deactivation events, Deactivation Timeout or a combination of the two.

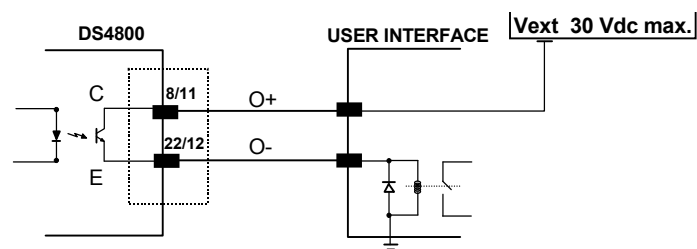

Figure 70 - Open Emitter Output Connections

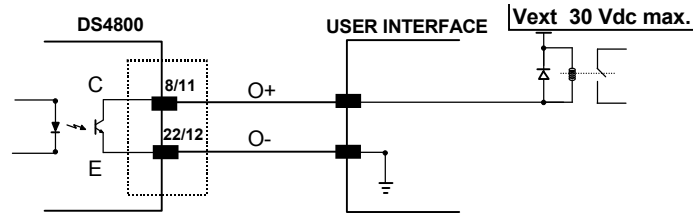

Figure 71 - Open Collector Output Connections

$V_{CE} \text{ max} = 30 \text{ Vdc}$

$I \text{ max} = 40 \text{ mA continuous; } 130 \text{ mA pulsed}$

5.7 USER INTERFACE - HOST

The following table contains the pinout for standard RS232 PC Host interface. For other user interface types please refer to their own manual.

RS232 PC-side connections			
<p>9-pin male connector</p>		<p>25-pin male connector</p>	
Pin	Name	Pin	Name
2	RX	3	RX
3	TX	2	TX
5	GND	7	GND
7	RTS	4	RTS
8	CTS	5	CTS

How To Build A Simple Interface Test Cable:

The following wiring diagram shows a simple test cable including power, external (push-button) trigger and PC RS232 COM port connections.

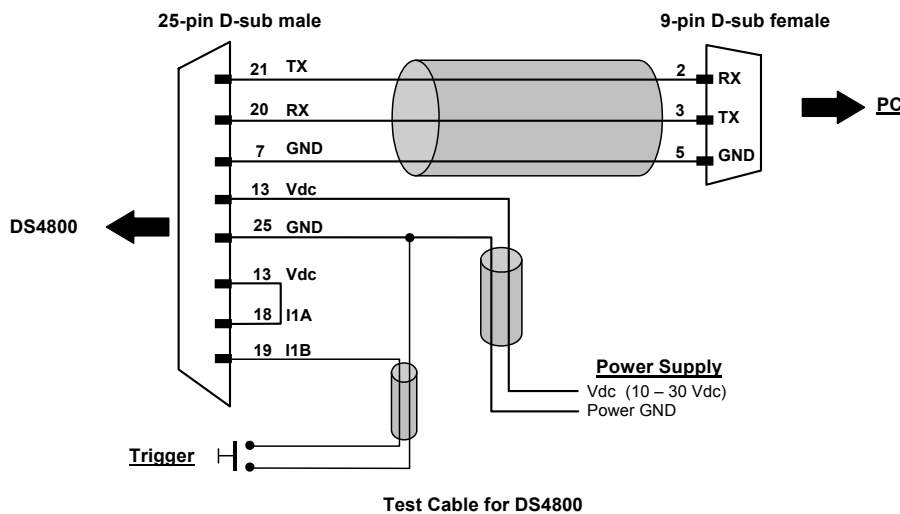

6 TYPICAL LAYOUTS

The following typical layouts refer to system hardware configurations. Dotted lines in the figures refer to optional hardware configurations within the particular layout.

These layouts also require the correct setup of the software configuration parameters. Complete software configuration procedures can be found in the **Guide To Rapid Configuration** in the Genius™ Help On Line.

6.1 POINT-TO-POINT

In this layout the data is transmitted to the Host on the main serial interface. A Genius™ based Host Mode programming can be accomplished either through the main interface or the Auxiliary interface.

In Local Echo communication mode, data is transmitted on the RS232 auxiliary interface independently from the main interface selection.

When On-Line Operating mode is used, the scanner is activated by an External Trigger (photoelectric sensor) when the object enters its reading zone.

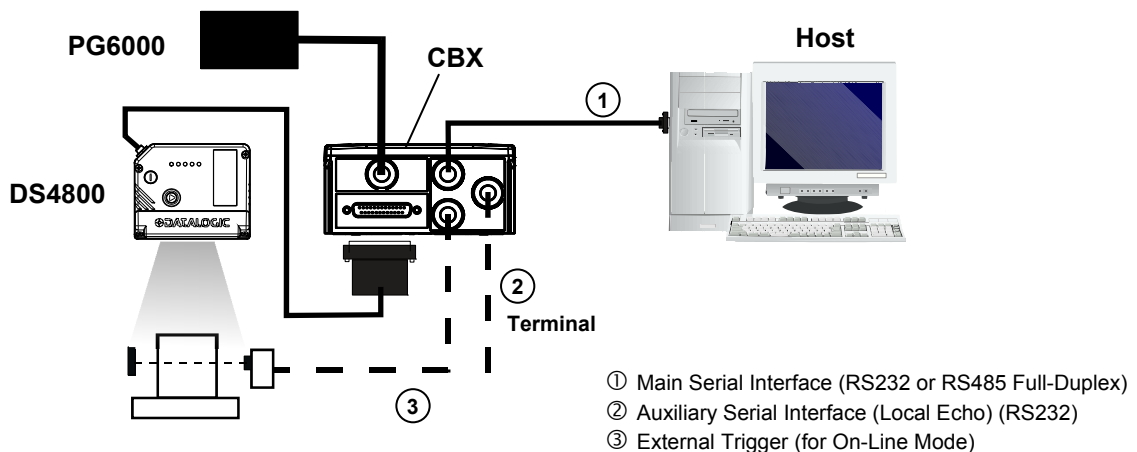

Figure 72 – Serial Interface Point-to-Point Layout

In this layout a single scanner functions as a Slave node on a Fieldbus network. The data is transmitted to the Host through an accessory Fieldbus interface board installed inside the CBX500 connection box.

Scanner configuration can be accomplished through the Auxiliary interface using the Genius™ configuration program or Genius™ based Host Mode programming.

In Local Echo communication mode, data is transmitted on the RS232 auxiliary interface independently from the Fieldbus interface selection.

When On-Line Operating mode is used, the scanner is activated by an External Trigger (photoelectric sensor) when the object enters its reading zone.

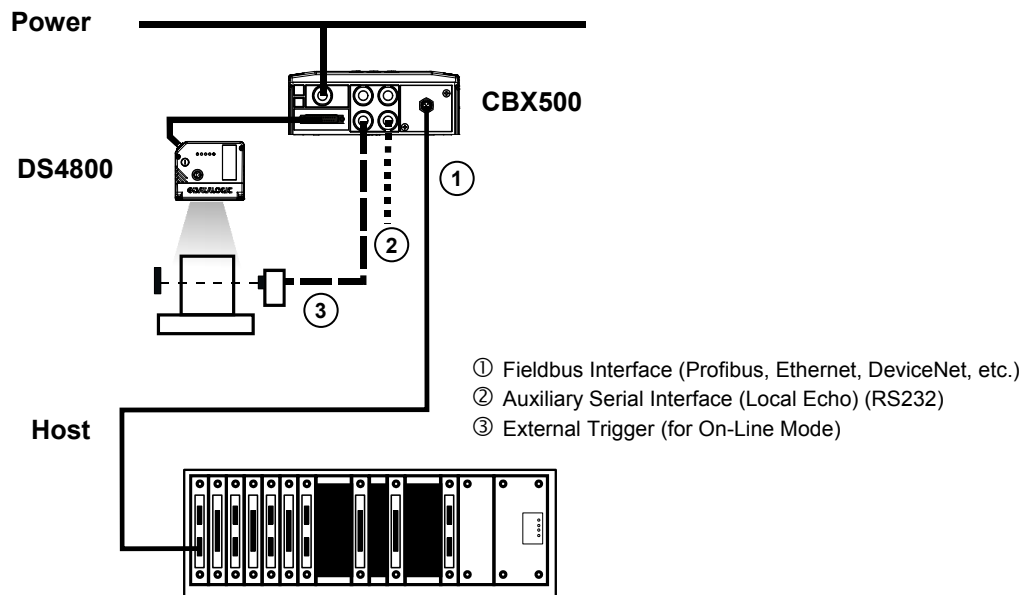

Figure 73 – Fieldbus Interface Point-to-Point Layout

6.2 PASS-THROUGH

Pass-through mode allows two or more devices to be connected to a single external serial interface.

Each DS4800 transmits the messages received by the Auxiliary interface onto the Main interface. All messages will be passed through this chain to the host.

When On-Line Operating mode is used, the scanner is activated by an External Trigger (photoelectric sensor) when the object enters its reading zone.

Applications can be implemented to connect a device such as a hand-held reader to the Auxiliary port of the last scanner in the chain for manual code reading capability.

The Main and Auxiliary ports are connected as shown in the figure below:

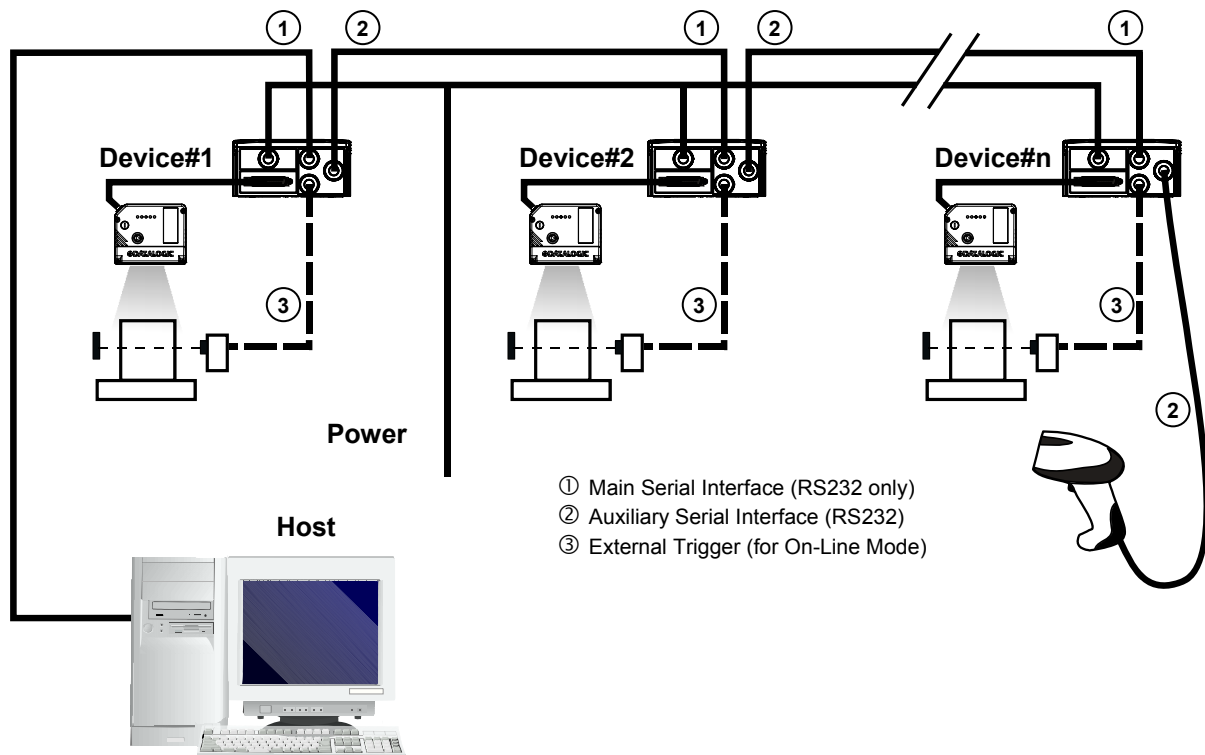

Figure 74 – Pass-Through Layout

An alternative Pass-Through layout allows the more efficient ID-NET™ network to be used. This layout is really an ID-NET Master/Slave Multidata layout which also allows **each** scanner (Master and Slaves) to accept input on the Auxiliary interface, for example to connect a device such as a hand-held reader for manual code reading capability.

Each DS4800 transmits its own messages plus any messages received by its Auxiliary interface onto the ID-NET™ interface. The Master passes all messages to the Host.

When On-Line Operating mode is used, the scanner is activated by an External Trigger (photoelectric sensor) when the object enters its reading zone.

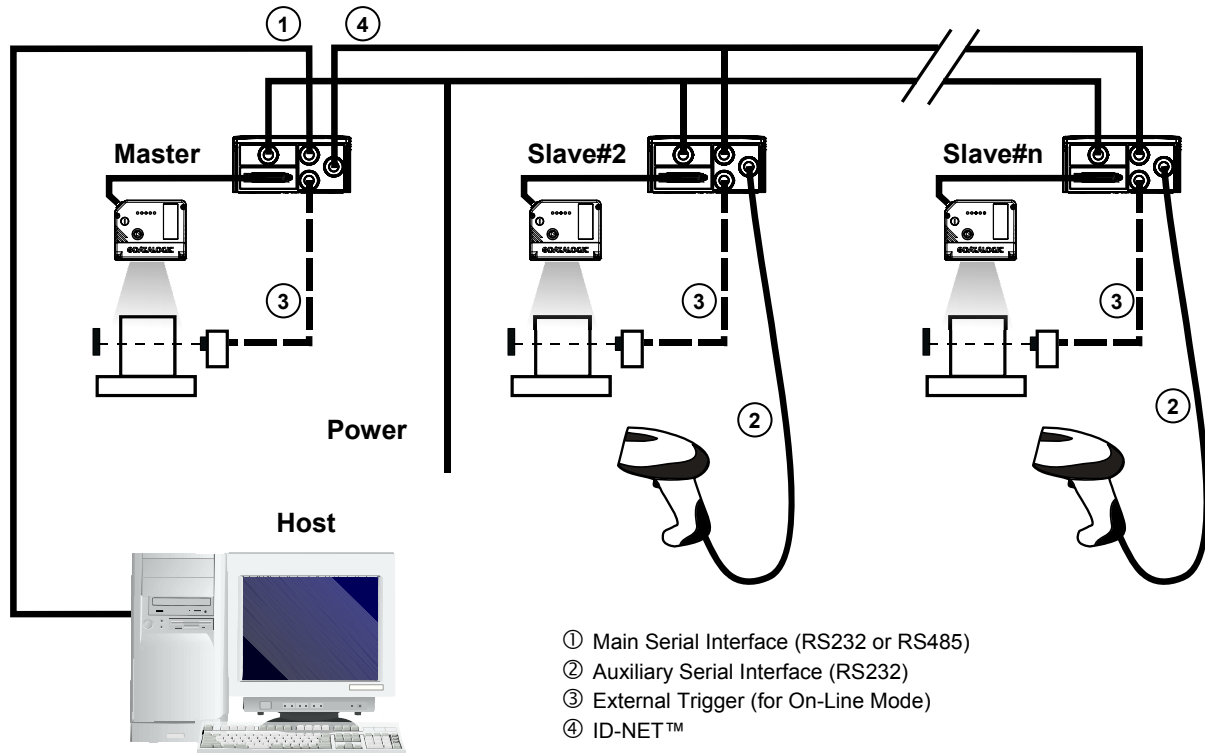

Figure 75 – Pass-Through On ID-NET™ Layout

6.3 ID-NET™

The ID-NET™ connection is used to collect data from several scanners to build a multi-point or a multi-sided reading system; there can be one master and up to 31 slaves connected together.

The slave scanners are connected together using the ID-NET™ interface. Every slave scanner must have an ID-NET™ address in the range 1-31.

The master scanner is also connected to the Host on the RS232/RS485 main serial interface.

For a Master/Slave Synchronized layout the External Trigger signal is unique to the system; there is a single reading phase and a single message from the master scanner to the Host computer. **It is not necessary to bring the External Trigger signal to all the scanners.**

The main, auxiliary, and ID-NET™ interfaces are connected as shown in the figure below.

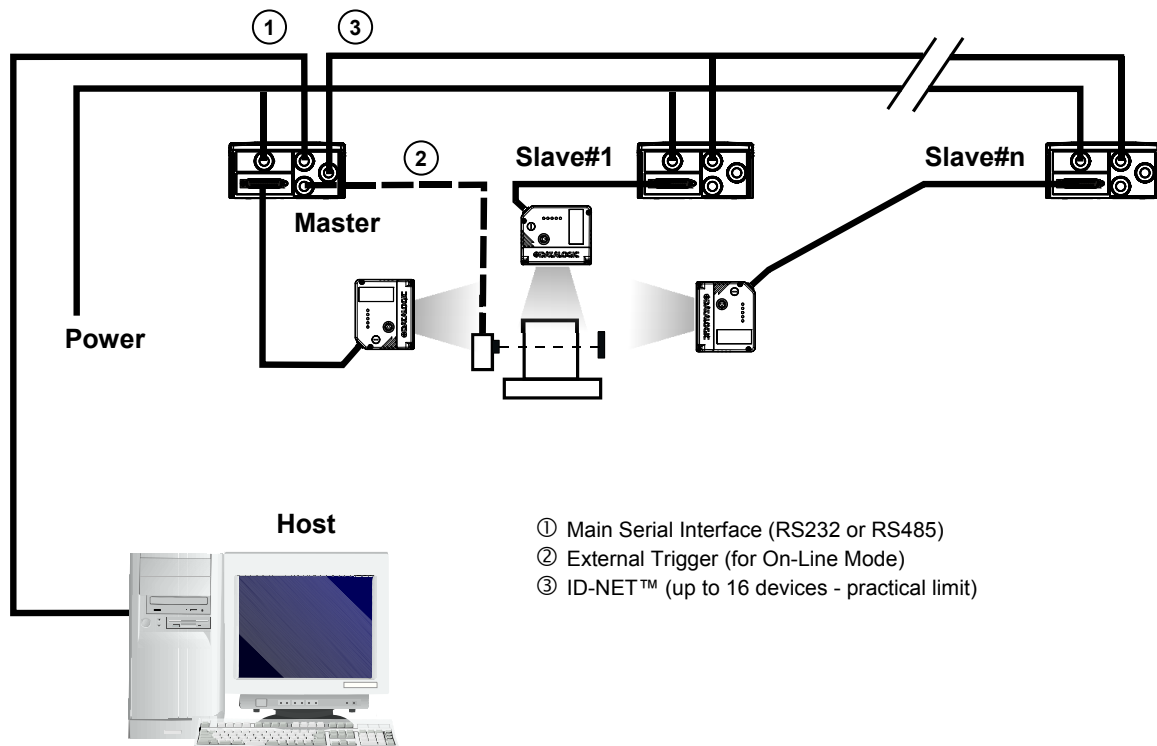

Figure 76 – ID-NET™ M/S Synchronized Layout

For a Master/Slave Multidata layout each scanner has its own reading phase independent from the others; each single message is sent from the master scanner to the Host computer.

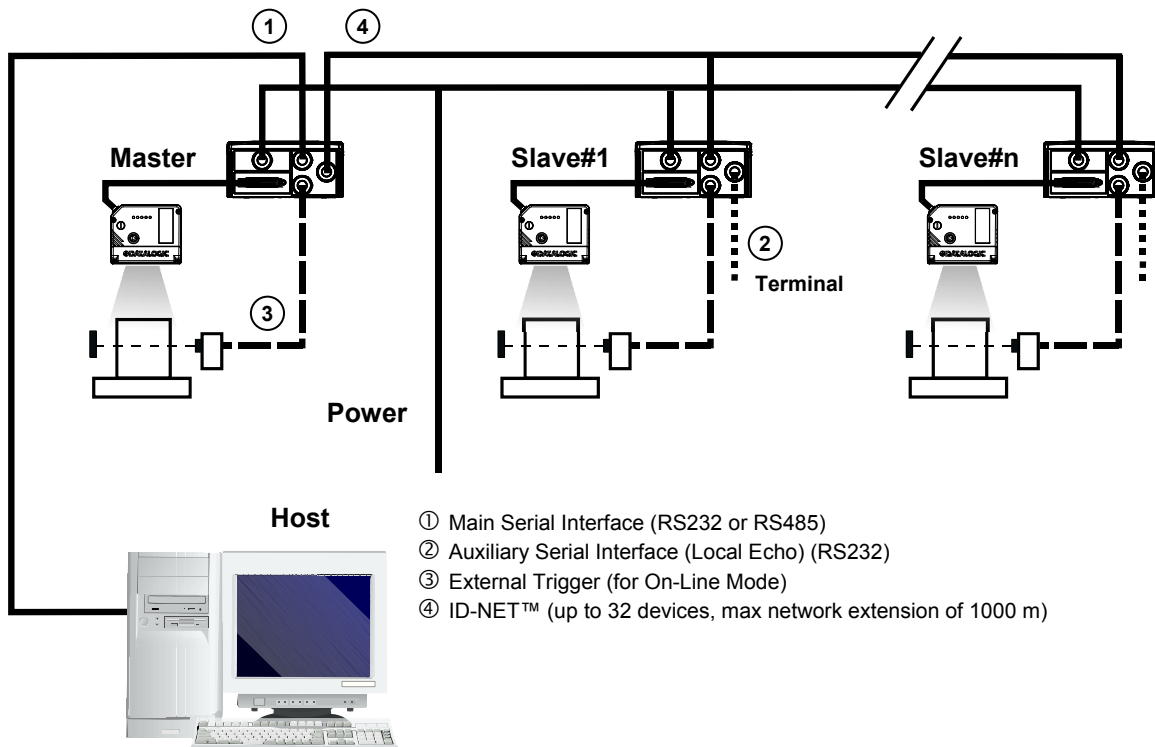

Figure 77 – ID-NET™ M/S Multidata



NOTE

The auxiliary serial interface of the slave scanners can be used in Local Echo communication mode to control any single scanner (visualize collected data) or to configure it using the Genius™ utility or the Genius™ based Host Mode programming procedure.

The ID-NET™ termination resistor switches must be set to ON only in the first and last CBX connection box.

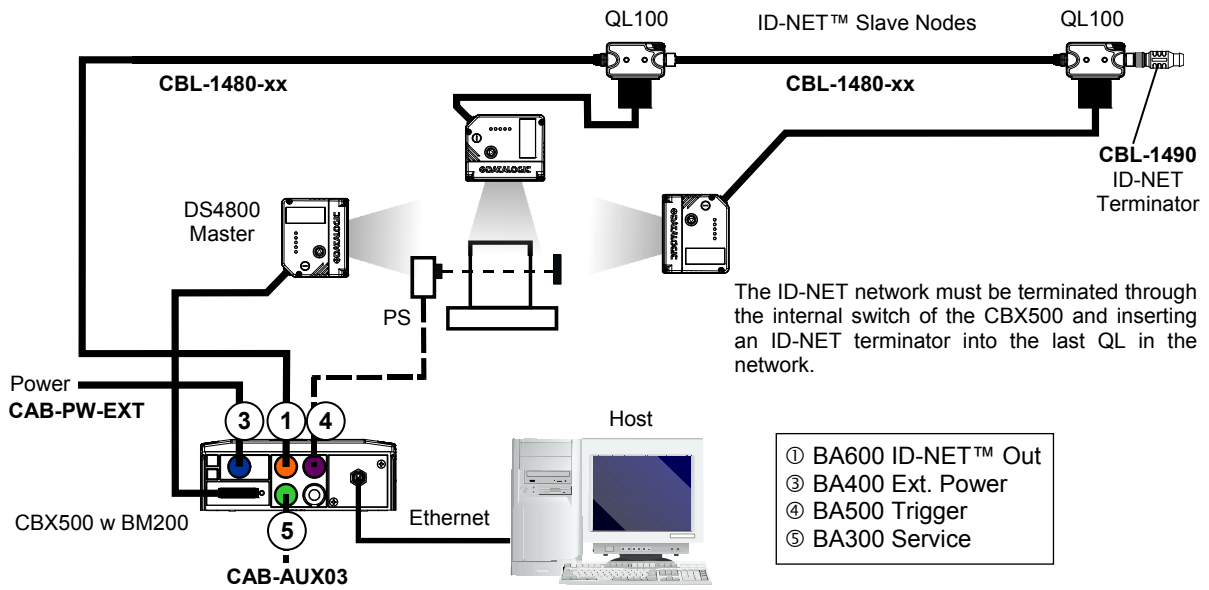

**Figure 78 – ID-NET™ M/S Synchronized Layout
 DS4800 Master with CBX500 + DS4800 Slaves with QL100**

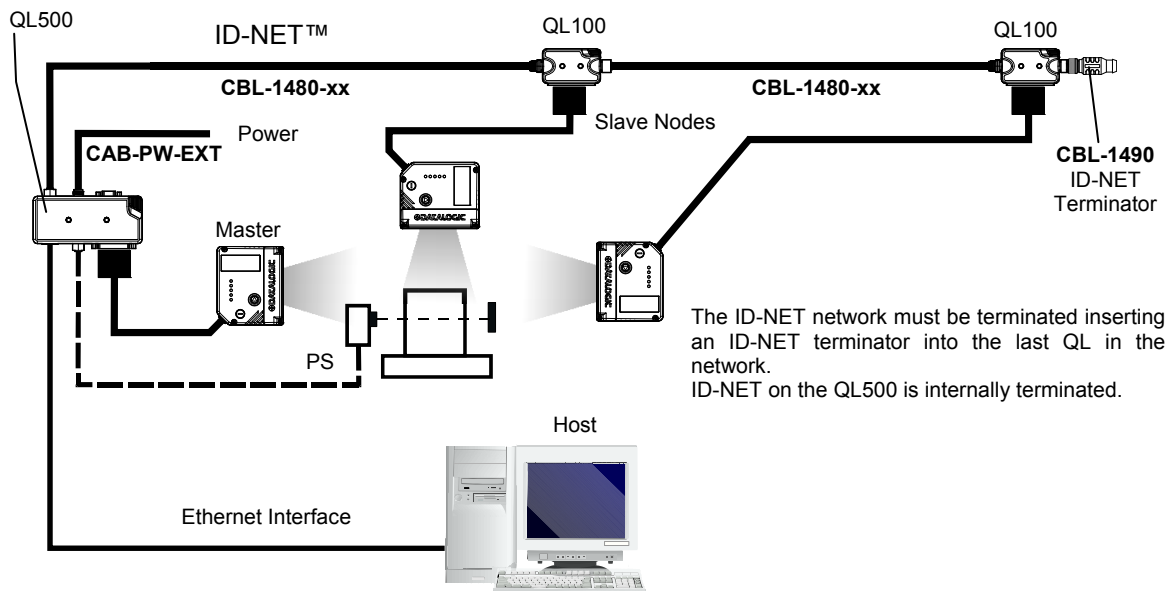
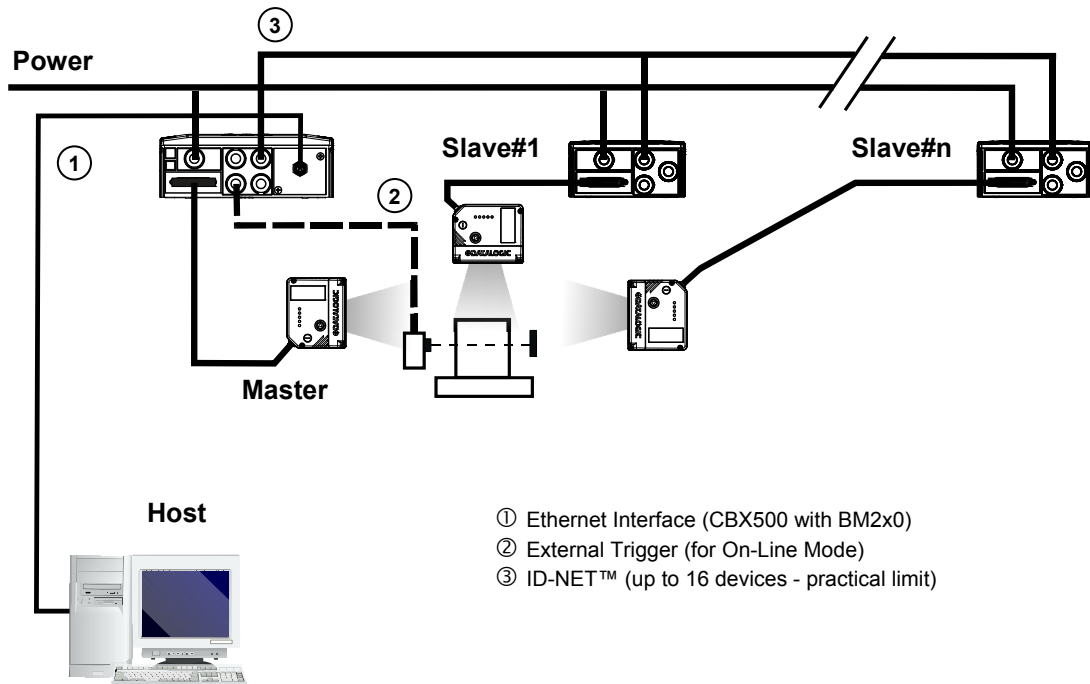

**Figure 79 – ID-NET™ M/S Synchronized Layout
 DS4800 Master with QL500 + DS4800 Slaves with QL100**

The Master scanner can communicate to the Host as a Slave node on an Ethernet TCP/IP network. This example requires using the accessory BM2x0 Ethernet interface board installed inside the CBX500 connection box.

System configuration can be accomplished through the Auxiliary interface of the Master scanner (internal CBX500 9-pin connector) using the Genius™ configuration program or Genius™ based Host Mode programming.

Configuration can also be accomplished in Genius directly through the Ethernet network. In this case initial connection can be made using Programming Barcodes.



**Figure 80 – ID-NET™ M/S Synchronized Layout
DS4800 Master with BM200/210 TCP/IP Ethernet Interface to Host**

Alternatively, the Master scanner can communicate to the Host as a Slave node on a Fieldbus network. This requires using an accessory Fieldbus interface board installed inside the CBX500 connection box.

System configuration can be accomplished through the Auxiliary interface of the Master scanner (internal CBX500 9-pin connector) using the Genius™ configuration program or Genius™ based Host Mode programming.

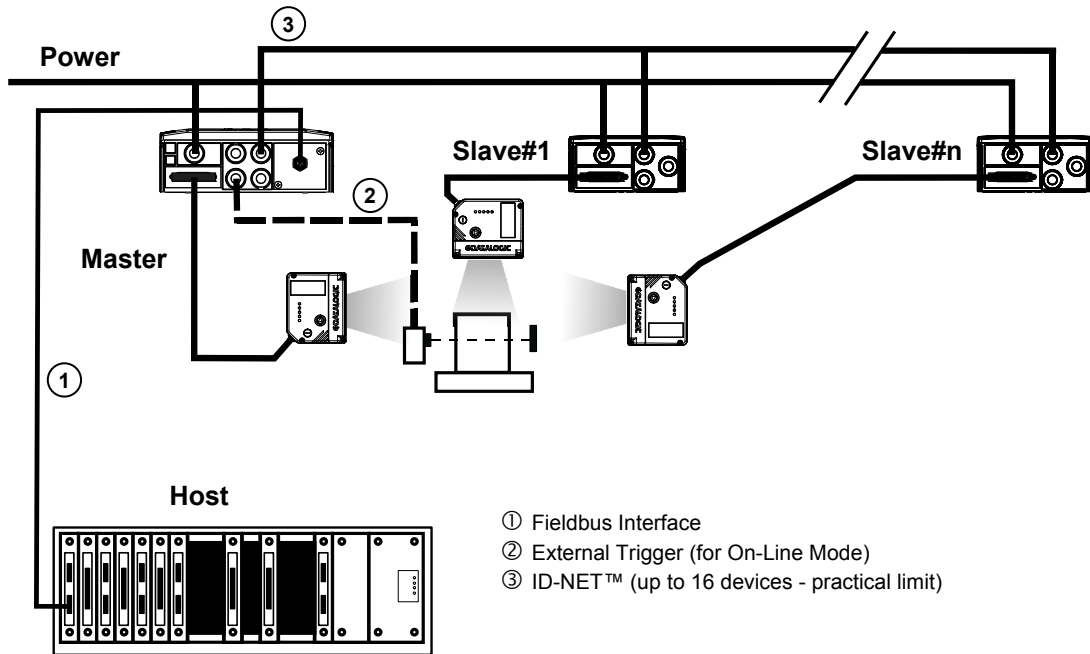

Figure 81 – ID-NET™ Fieldbus M/S Synchronized Layout

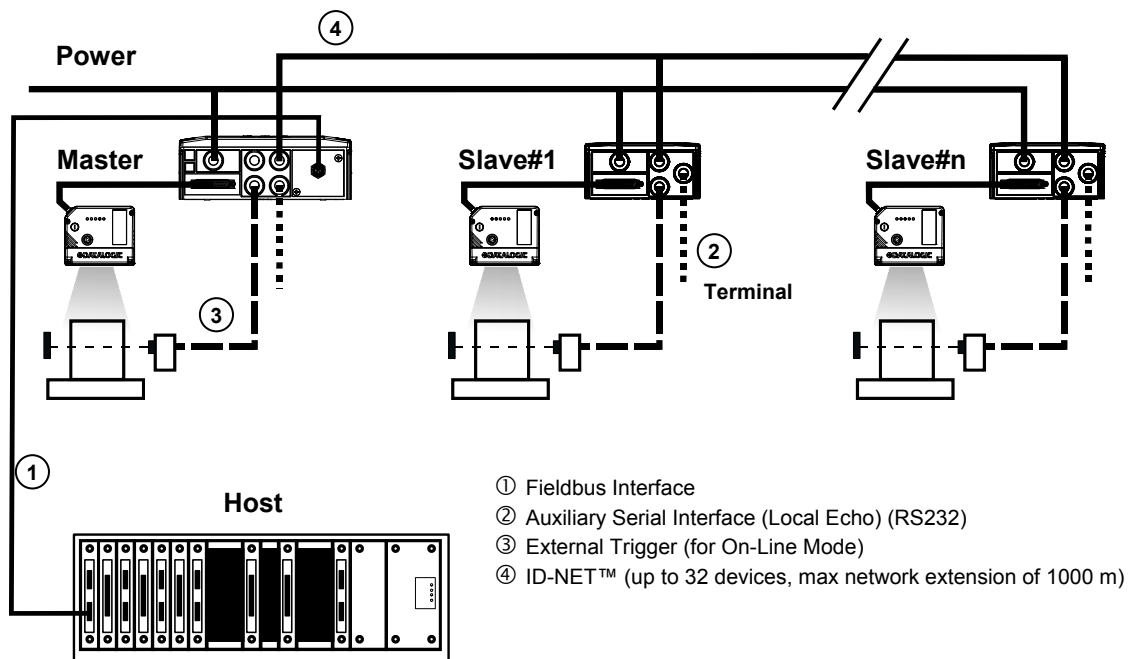

Figure 82 – ID-NET™ Fieldbus M/S Multidata

6.4 RS232 MASTER/SLAVE



NOTE

This interface is provided for backward compatibility. We recommend using the more efficient ID-NET™ network for Master/Slave or Multiplexer layouts.

The RS232 master/slave connection is used to collect data from several scanners to build either a multi-point or a multi-sided reading system; there can be one master and up to 9 slaves connected together.

The Slave scanners use RS232 only on the main and auxiliary serial interfaces. Each slave DS4800 transmits the messages received by the auxiliary interface onto the main interface. All messages will be passed through this chain to the Master.

The Master scanner is connected to the Host on the RS232/RS485 main serial interface.

There is a single reading phase and a single message from the master scanner to the Host computer.

Either On-Line or Serial On-Line Operating modes can be used in this layout.

When On-Line Operating mode is used, the external trigger signal is unique to the system, however it is not necessary to bring the external trigger signal to the Slave scanners.

The main and auxiliary ports are connected as shown in the figure below.

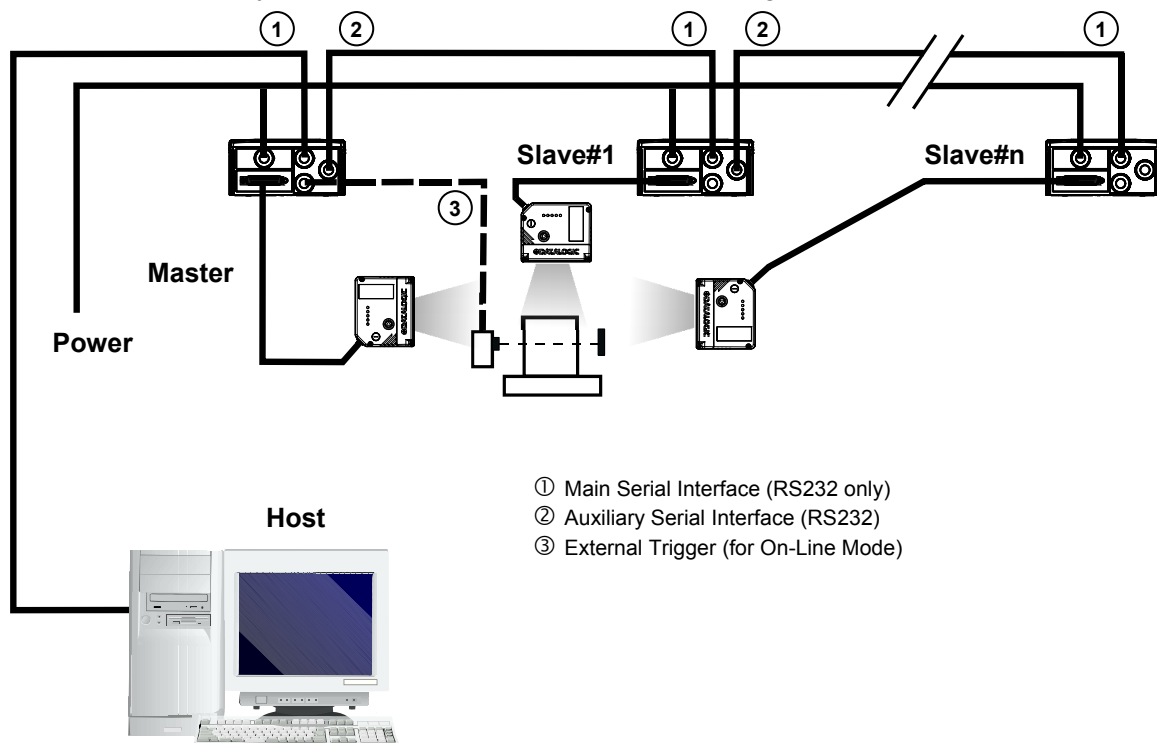

Figure 83 – RS232 Master/Slave Layout

6.5 MULTIPLEXER LAYOUT



NOTE

This interface is provided for backward compatibility. We recommend using the more efficient ID-NET™ network for Master/Slave or Multiplexer layouts.

Each scanner is connected to a Multiplexer (for example MX4000) with the RS485 half-duplex main interface through a CBX connection box.

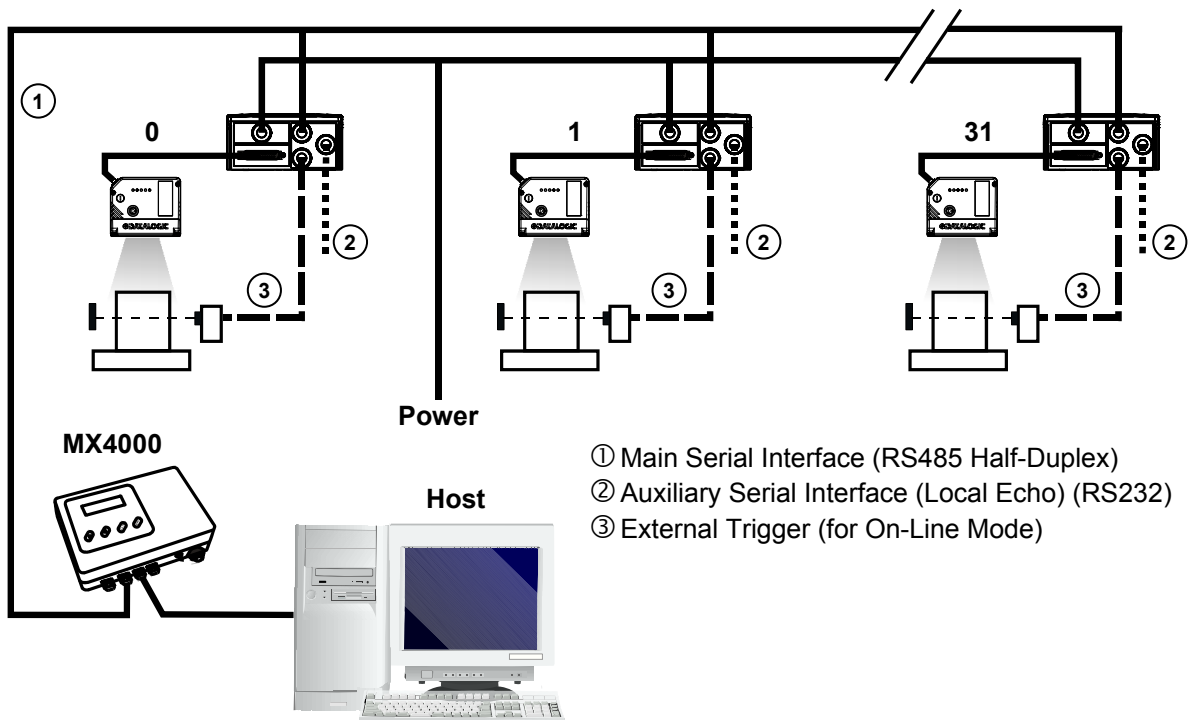

Figure 84 - Multiplexer Layout

The auxiliary serial interface of the slave scanners can be used in Local Echo communication mode to control any single scanner (visualize collected data) or to configure it using the Genius™ utility or Genius™ based Host Mode programming procedure.

Each scanner has its own reading phase independent from the others. When On-Line Operating mode is used, the scanner is activated by an External Trigger (photoelectric sensor) when the object enters its reading zone.

7 READING FEATURES

7.1 ADVANCED CODE RECONSTRUCTION (ACR™ 4)

The traditional way of barcode reading could be called “Linear Reading”. In this case, the laser beam crosses the barcode symbol from its beginning to its end as shown in the following figure:



Figure 85 – Linear Reading

In Advanced Code Reconstruction mode it is no longer necessary for the laser beam to cross the label from the start to the end. With just a set of partial scans on the label (obtained using the motion of the label itself), the scanner is able to “reconstruct” the barcode. A typical set of partial scans is shown in the figure below:

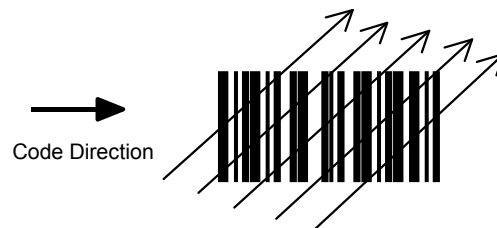

Figure 86 – Partial Scans

None of the partial scans contains the whole label. The decoder aligns each partial scan correctly and combines them in order to obtain the entire code.

The alignment is performed by calculating the time difference from one partial scan to another using a reference code element.

ACR4 therefore has an intrinsic ability to increase the reading percentage of damaged codes as in the examples below:



Figure 87 – ACR4™ Readable Codes

7.1.1 Tilt Angle for Advanced Code Reconstruction

The most important parameter in Advanced Code Reconstruction is the value of the maximum tilt angle (α maximum) under which the code reconstruction process is still possible.

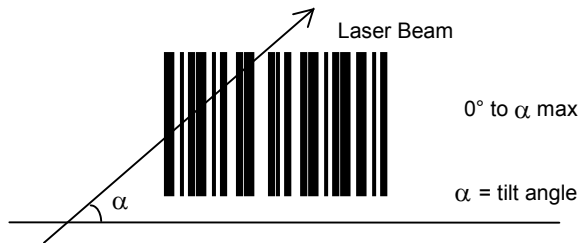

Figure 88 – Tilt Angle

The decoder will be able to read the label with a tilt angle between $+\alpha$ max and $-\alpha$ max as shown in the following figure:

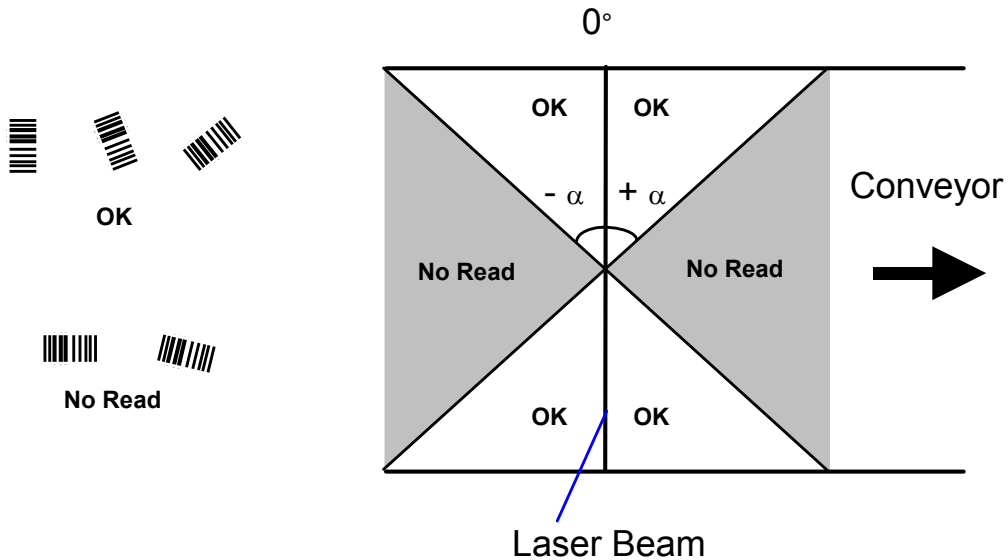



Figure 89 – Reading Zones with α Max

 **NOTE** While tilt angles of 45° can be obtained, DS4800 scanners are not designed to create omni-directional reading stations using two scanners in an X-pattern.

7.1.2 Advanced Code Reconstruction Reading Conditions

The following tables describe the minimum code height requirements (in mm) for standard ACR4™ applications depending on the code symbology and the given reading conditions.

- ANSI Grade B minimum
- 800 scans/sec
- three code symbologies enabled simultaneously
- uniform background

2/5 Interleaved		Minimum Code Height for ACR4 Reading (mm)											
		45° max						30° max					
Conveyor Speed (m/s)		0.5	1	1.5	2	2.5	3	0.5	1	1.5	2	2.5	3
Code Resolution (mm)	0.25	12	15	18	21	23	26	8	11	13	15	17	19
	0.30	14	16	19	22	25	28	9	11	14	16	18	20
	0.33	15	17	20	23	26	29	10	12	14	16	19	21
	0.38	16	19	22	24	27	30	11	13	15	17	20	22
	0.50	20	22	25	28	31	34	13	15	17	19	22	24
	0.72	26	29	32	35	37	40	17	19	21	23	25	28
	1.00	35	37	40	43	46	49	21	24	26	28	30	33

Ratio 3:1

Table 1

Code 39		Minimum Code Height for ACR4 Reading (mm)											
		45° max						30° max					
Conveyor Speed (m/s)		0.5	1	1.5	2	2.5	3	0.5	1	1.5	2	2.5	3
Code Resolution (mm)	0.25	11	14	16	19	22	25	8	10	12	14	16	19
	0.30	12	15	18	20	23	26	8	10	13	15	17	19
	0.33	13	16	18	21	24	27	9	11	13	15	18	20
	0.38	14	17	20	22	25	28	9	12	14	16	18	21
	0.50	17	20	22	25	28	31	11	13	16	18	20	22
	0.72	22	25	28	31	33	36	14	16	19	21	23	25
	1.00	29	32	35	37	40	43	18	20	23	25	27	29

Ratio 3:1; Interdigit = Module Size

Table 2

Code 128 – EAN 128		Minimum Code Height for ACR4 Reading (mm)											
		45° max						30° max					
Conveyor Speed (m/s)		0.5	1	1.5	2	2.5	3	0.5	1	1.5	2	2.5	3
Code Resolution (mm)	0.25	9	12	15	18	21	23	7	9	11	13	16	18
	0.30	10	13	16	19	22	24	7	9	12	14	16	18
	0.33	11	14	16	19	22	25	8	10	12	14	17	19
	0.38	12	15	17	20	23	26	8	10	13	15	17	19
	0.50	14	17	20	22	25	28	9	12	14	16	18	21
	0.72	18	21	24	27	29	32	12	14	16	19	21	23
	1.00	24	26	29	32	35	38	15	17	19	22	24	26

Table 3

Codabar		Minimum Code Height for ACR4 Reading (mm)											
		45° max						30° max					
Conveyor Speed (m/s)		0.5	1	1.5	2	2.5	3	0.5	1	1.5	2	2.5	3
Code Resolution (mm)	0.25	10	12	15	18	21	24	7	9	11	14	16	18
	0.30	11	13	16	19	22	25	7	10	12	14	16	19
	0.33	11	14	17	20	22	26	8	10	12	14	17	19
	0.38	12	15	18	21	23	26	8	11	13	15	17	20
	0.50	15	17	20	23	26	29	10	12	14	16	19	21
	0.72	19	22	25	27	30	33	12	15	17	19	21	24
	1.00	25	27	30	33	36	39	16	18	20	22	25	27

Ratio 3:1; Interdigit = Module Size

Table 4

EAN 8-13, UPC-A		Minimum Code Height for ACR4 Reading (mm)											
		45° max						30° max					
Conveyor Speed (m/s)		0.5	1	1.5	2	2.5	3	0.5	1	1.5	2	2.5	3
Code Resolution (mm)	0.25	9	12	15	18	21	23	7	9	11	13	16	18
	0.30	10	13	16	19	22	24	7	9	12	14	16	18
	0.33	11	14	16	19	22	25	8	10	12	14	17	19
	0.38	12	15	17	20	23	26	8	10	13	15	17	19
	0.50	14	17	20	22	25	28	9	12	14	16	18	21
	0.72	18	21	24	27	29	32	12	14	16	19	21	23
	1.00	24	26	29	32	35	38	15	17	19	22	24	26

Table 5



NOTE

To maximize scanner performance in Advanced Code Reconstruction Reading applications:

- *enable only the code symbologies that will actually be used in the application and disable any code symbologies that will not be used in the application*
- *reconstruct only one code label at a time*

7.2 LINEAR CODE READING

The number of scans performed on the code by the DS4800 and therefore the decoding capability is influenced by the following parameters:

- number of scans per second
- code motion speed
- label dimensions
- scan direction with respect to code motion

At least 5 scans during the code passage should be allowed to ensure a successful read.

7.2.1 Step-Ladder Mode

If scanning is perpendicular to the code motion direction (Figure 90), the number of effective scans performed by the reader is given by the following formula:

$$SN = [(LH/LS) * SS] - 2$$

Where: SN = number of effective scans
 LH = label height (in mm)
 LS = label movement speed in (mm/s)
 SS = number of scans per second

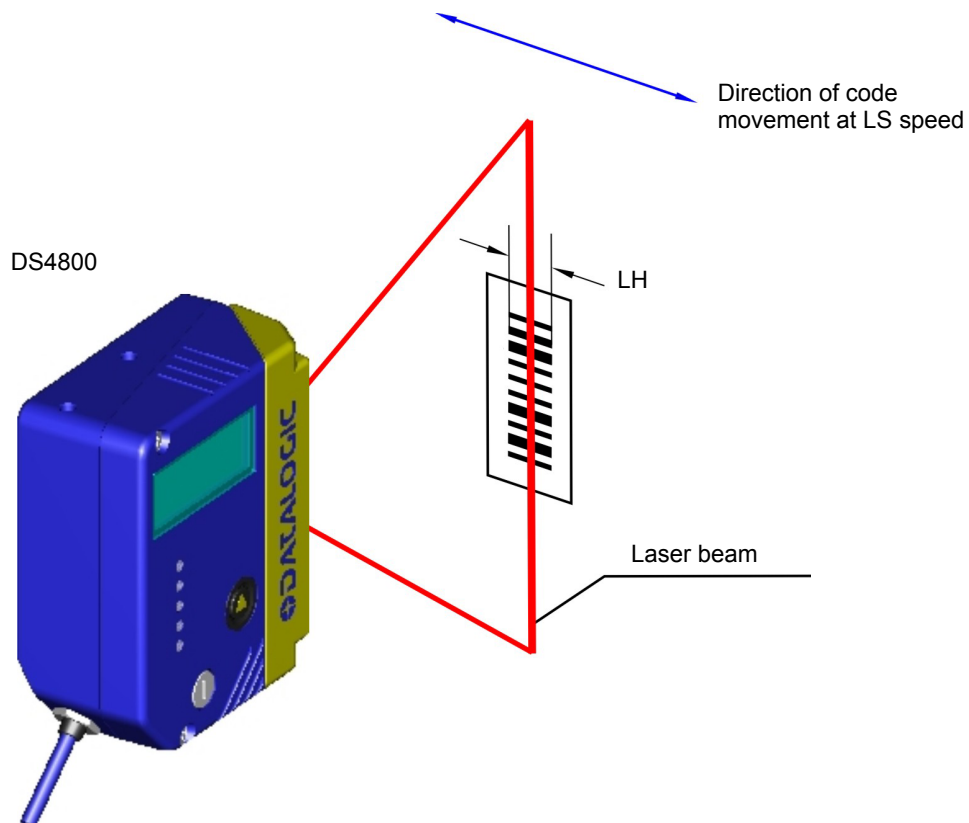

Figure 90 - "Step-Ladder" Scanning Mode

For example, the DS4800 (800 scans/sec.) for a 25 mm high code moving at 1250 mm/s performs:

$$[(25/1250) * 800] - 2 = 14 \text{ effective scans.}$$

7.2.2 Picket-Fence Mode

If scanning is parallel to the code motion, (Figure 91), the number of effective scans is given by the following formula:

$$SN = [((FW-LW)/LS) * SS] - 2$$

Where: SN = number of effective scans
 FW = reading field width (in mm)
 LW = label width (in mm)
 LS = label movement speed (in mm/s)
 SS = scans per second

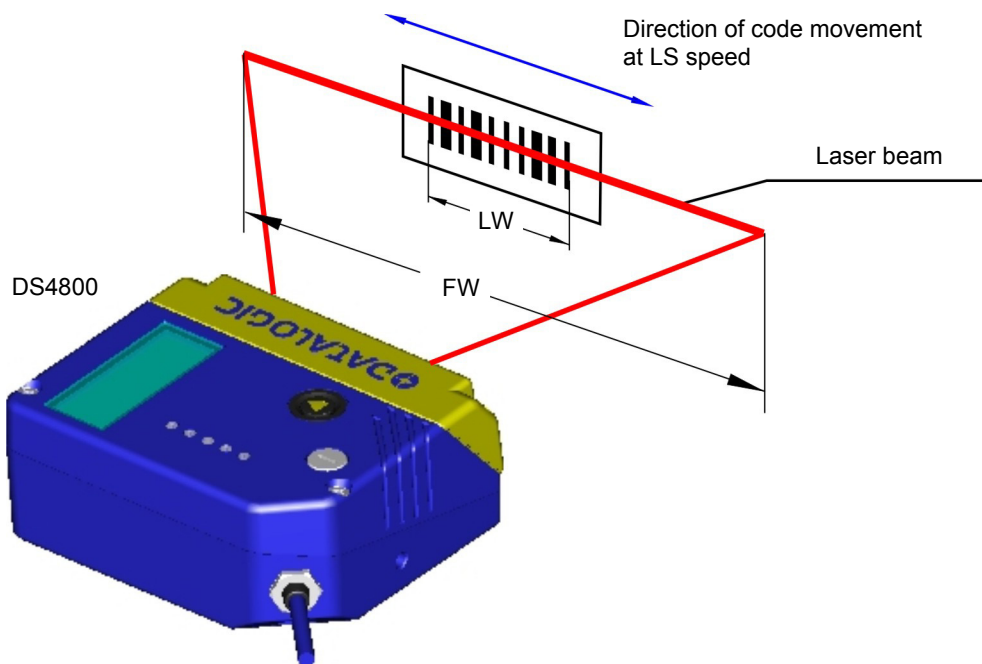

Figure 91 - "Picket-Fence" Scanning Mode

For example, for a 60 mm wide code moving in a point where the reading field is 160 mm wide at a 2000 mm/s speed, the DS4800 (800 scans per sec.), performs:

$$[((160-60)/2000) * 800] - 2 = 38 \text{ effective scans}$$

7.3 PERFORMANCE

The reading performance of the DS4800 scanner depends in part on the focus position setting.

Focus	Max Code Resolution	Speed
	mm (mils)	scans/s
F = 30 Near	0.20 (8)	800
F = 40 Medium	0.30 (12)	800
F = 60 Far	0.38 (15)	800

X0XX (Standard Models)	
Focus	Reading Distance
F = 30 Near	21 cm (8.3 in) - 47 cm (18.5 in) on 0.50 mm (20 mils) codes
F = 40 Medium	27 cm (10.6 in) - 68 cm (26.8 in) on 0.50 mm (20 mils) codes
F = 60 Far	40 cm (16.7 in) - 100 cm (39.4 in) on 0.50 mm (20 mils) codes

X1XX (OM Models)	
Focus	Reading Distance
F = 30 Near	20 cm (7.9 in) - 43 cm (16.9 in) on 0.50 mm (20 mils) codes
F = 40 Medium	26 cm (10.2 in) - 64 cm (25.2 in) on 0.50 mm (20 mils) codes
F = 60 Far	39 cm (15.4 in) - 95 cm (37.4 in) on 0.50 mm (20 mils) codes

XXX5 (Subzero Models)	
Focus	Reading Distance
F = 30 Near	22 cm (8.7 in) - 45 cm (17.7 in) on 0.50 mm (20 mils) codes
F = 40 Medium	28 cm (11 in) - 65 cm (25.6 in) on 0.50 mm (20 mils) codes
F = 60 Far	41 cm (16.1 in) - 96 cm (37.8 in) on 0.50 mm (20 mils) codes

Refer to the diagrams in par. 7.4 for further details on the reading features.

For Standard and OM models, these diagrams are taken on various resolution sample codes at a 25 °C ambient temperature and depend on the conditions listed under each diagram.

Subzero model diagrams are based on an ambient temperature of -35 °C and depend on the conditions listed under each diagram.

7.4 READING DIAGRAMS

7.4.1 X0XX Standard Models

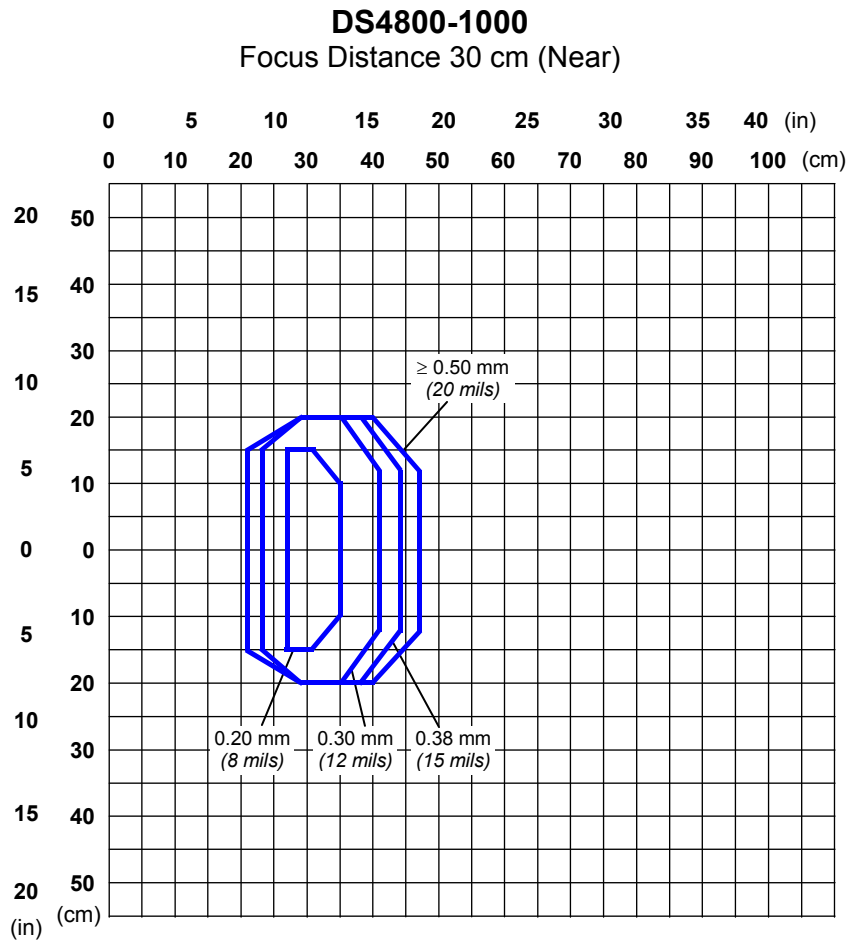

NOTE: (0,0) is the center of the laser beam output window.

CONDITIONS

- Code = Code 128
- PCS = 0.90
- "Pitch" angle = 0°
- "Skew" angle = 15°
- "Tilt" angle = 0° to 30°
- *Scan Speed = 800 scans/sec.
- *Reading Condition = Standard
- * Reading Mode = Linear

- Parameter selectable in Genius™

For Tilt angles of 45°, the reading performance is reduced by approximately the following values:

- Minimum reading distance: +20%
- Maximum reading distance: -30%
- Maximum reading width: -15%

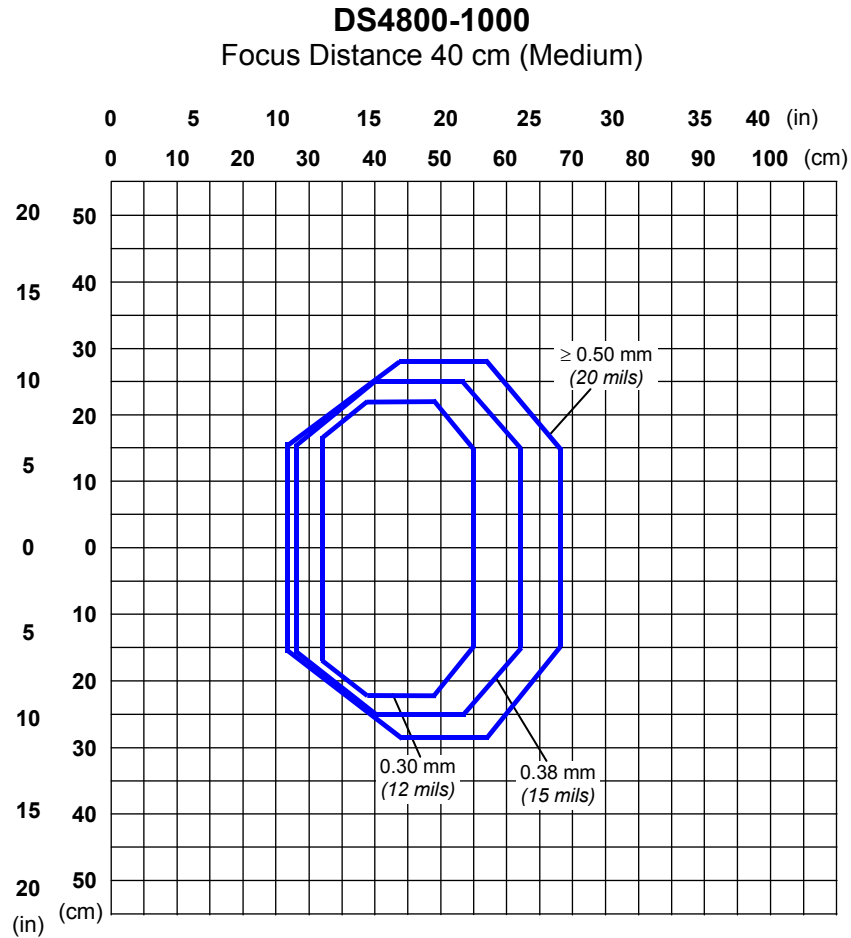

NOTE: (0,0) is the center of the laser beam output window.

CONDITIONS

Code	=	Code 128
PCS	=	0.90
"Pitch" angle	=	0°
"Skew" angle	=	15°
"Tilt" angle	=	0° to 30°
*Scan Speed	=	800 scans/sec.
*Reading Condition	=	Standard
* Reading Mode	=	Linear

* Parameter selectable in Genius™

For Tilt angles of 45°, the reading performance is reduced by approximately the following values:

Minimum reading distance: +20%
Maximum reading distance: -25%
Maximum reading width: -15%

DS4800-1000
Focus Distance 60 cm (Far)

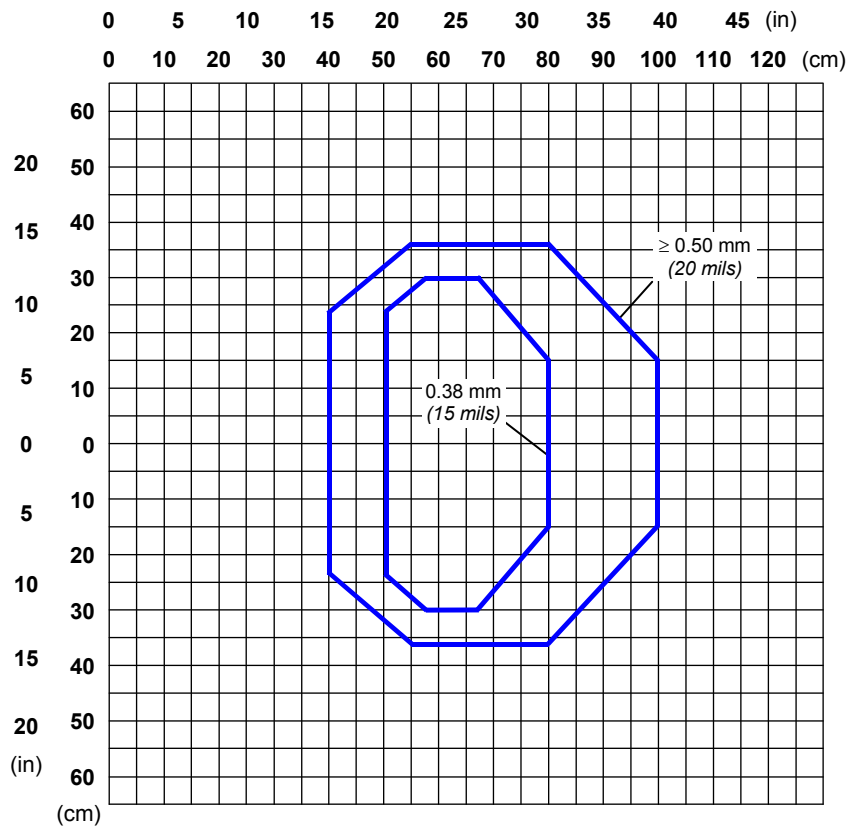

NOTE: (0,0) is the center of the laser beam output window.

CONDITIONS

- Code = Code 128
- PCS = 0.90
- "Pitch" angle = 0°
- "Skew" angle = 15°
- "Tilt" angle = 0° to 30°
- *Scan Speed = 800 scans/sec.
- *Reading Condition = Standard
- * Reading Mode = Linear

* Parameter selectable in Genius™

For Tilt angles of 45°, the reading performance is reduced by approximately the following values:

- Minimum reading distance: +20%
- Maximum reading distance: -15%
- Maximum reading width: -15%

7.4.2 X1XX Oscillating Mirror Models

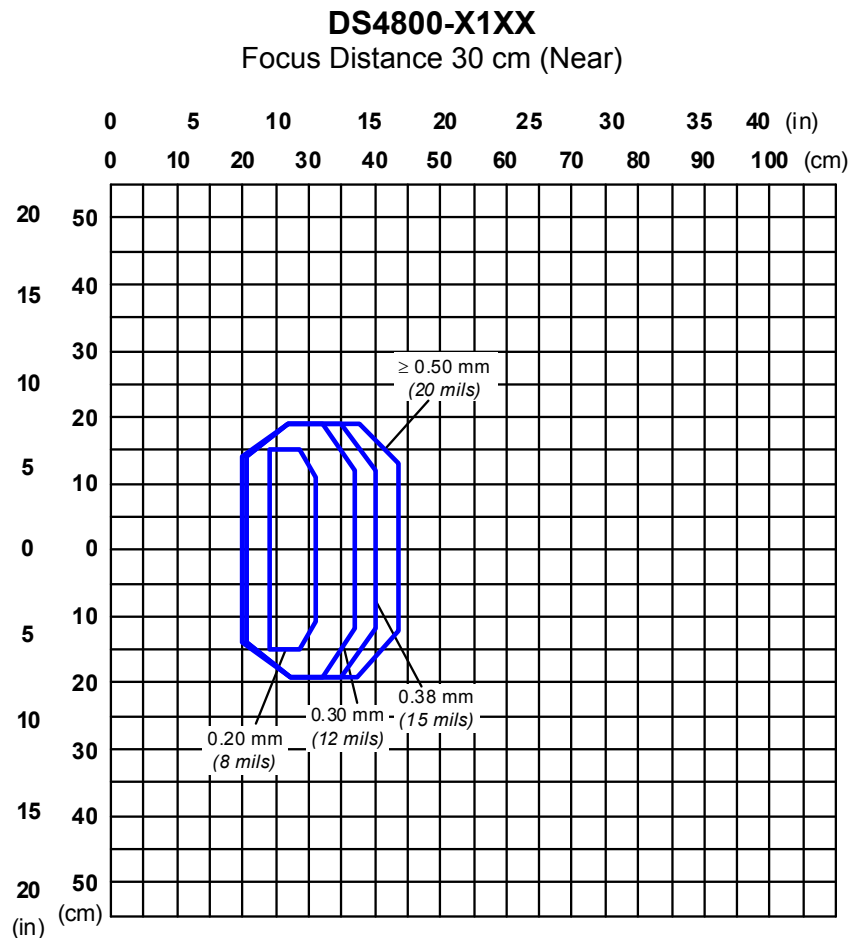

NOTE: (0,0) is the center of the laser beam output window.

CONDITIONS

Code	=	Code 128
PCS	=	0.90
"Pitch" angle	=	0°
"Skew" angle	=	15°
"Tilt" angle	=	0° to 30°
*Scan Speed	=	800 scans/sec.
*Reading Condition	=	Standard
* Reading Mode	=	Linear

- Parameter selectable in Genius™

For Tilt angles of 45°, the reading performance is reduced by approximately the following values:

Minimum reading distance: +20%

Maximum reading distance: -30%

Maximum reading width: -15%

DS4800-X1XX
Focus Distance 40 cm (Medium)

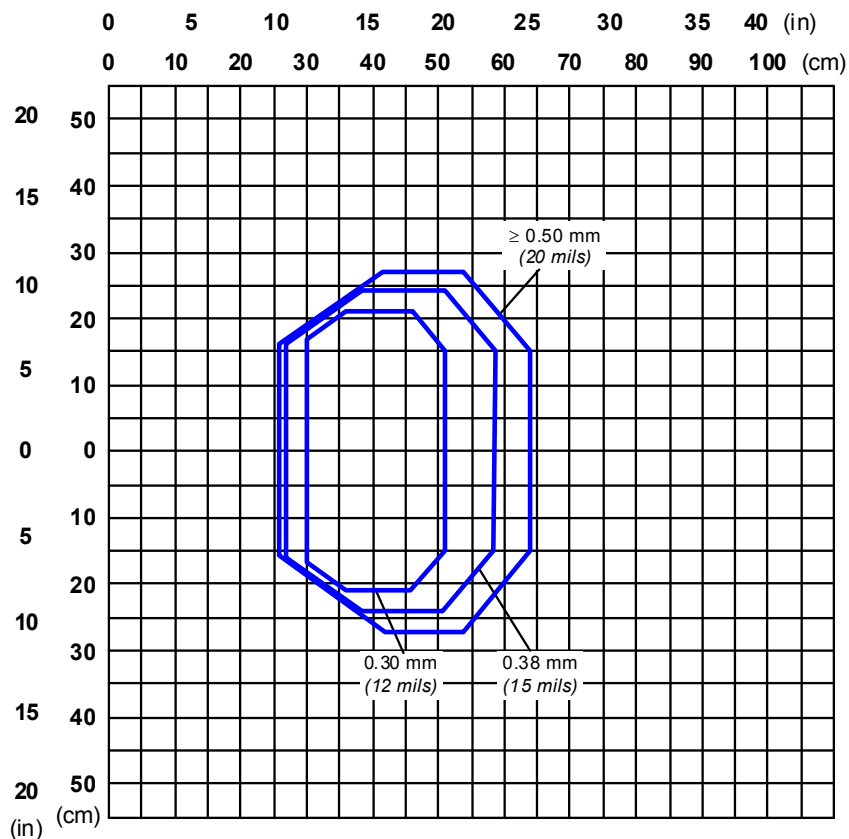

NOTE: (0,0) is the center of the laser beam output window.

CONDITIONS

- Code = Code 128
- PCS = 0.90
- "Pitch" angle = 0°
- "Skew" angle = 15°
- "Tilt" angle = 0° to 30°
- *Scan Speed = 800 scans/sec.
- *Reading Condition = Standard
- * Reading Mode = Linear

* Parameter selectable in Genius™

For Tilt angles of 45°, the reading performance is reduced by approximately the following values:

- Minimum reading distance: +20%
- Maximum reading distance: -25%
- Maximum reading width: -15%

DS4800-X1XX
Focus Distance 60 cm (Far)

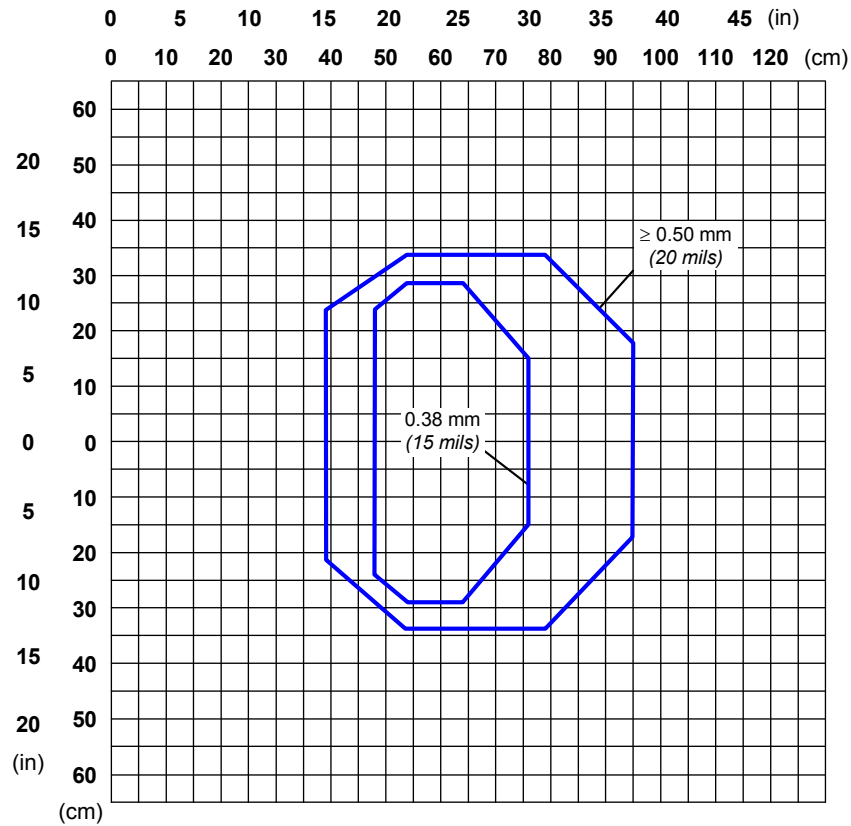

NOTE: (0,0) is the center of the laser beam output window.

CONDITIONS

Code	=	Code 128
PCS	=	0.90
"Pitch" angle	=	0°
"Skew" angle	=	15°
"Tilt" angle	=	0° to 30°
*Scan Speed	=	800 scans/sec.
*Reading Condition	=	Standard
* Reading Mode	=	Linear

* Parameter selectable in Genius™

For Tilt angles of 45°, the reading performance is reduced by approximately the following values:

- Minimum reading distance: +20%
- Maximum reading distance: -15%
- Maximum reading width: -15%

7.4.3 XXX5 Subzero Models

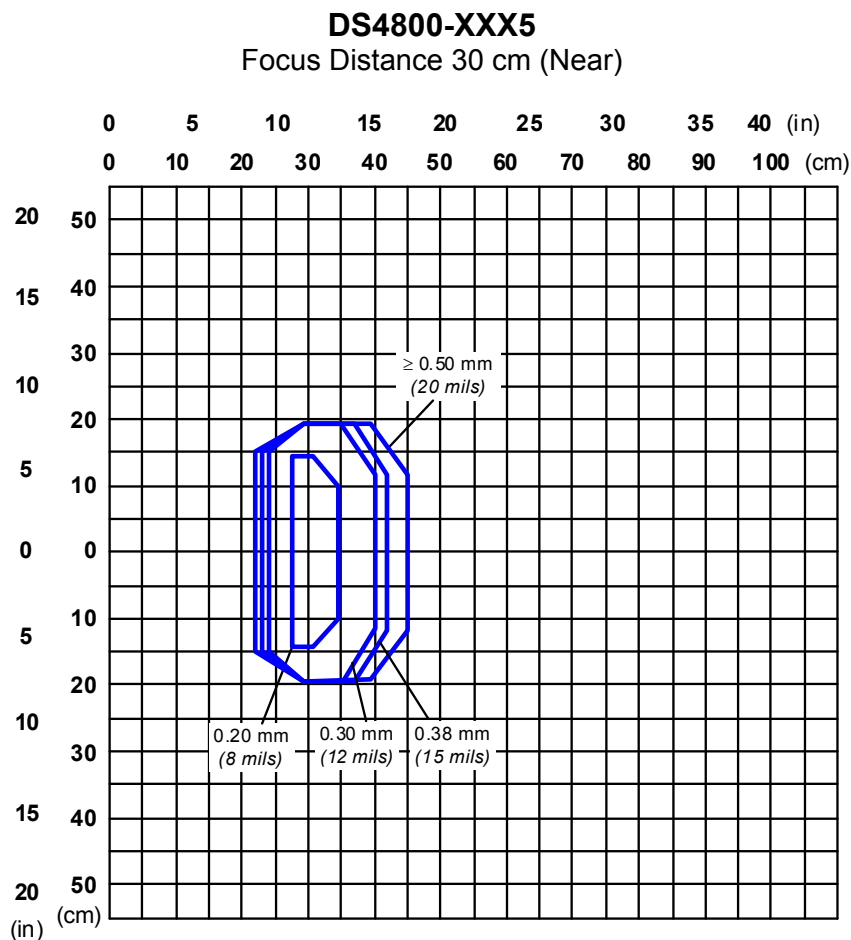

NOTE: (0,0) is the center of the laser beam output window.

CONDITIONS

- Code = Code 128
- PCS = 0.90
- "Pitch" angle = 0°
- "Skew" angle = 15°
- "Tilt" angle = 0° to 30°
- *Scan Speed = 800 scans/sec.
- *Reading Condition = Standard
- * Reading Mode = Linear

- Parameter selectable in Genius™

For Tilt angles of 45°, the reading performance is reduced by approximately the following values:

- Minimum reading distance: +20%
- Maximum reading distance: -30%
- Maximum reading width: -15%

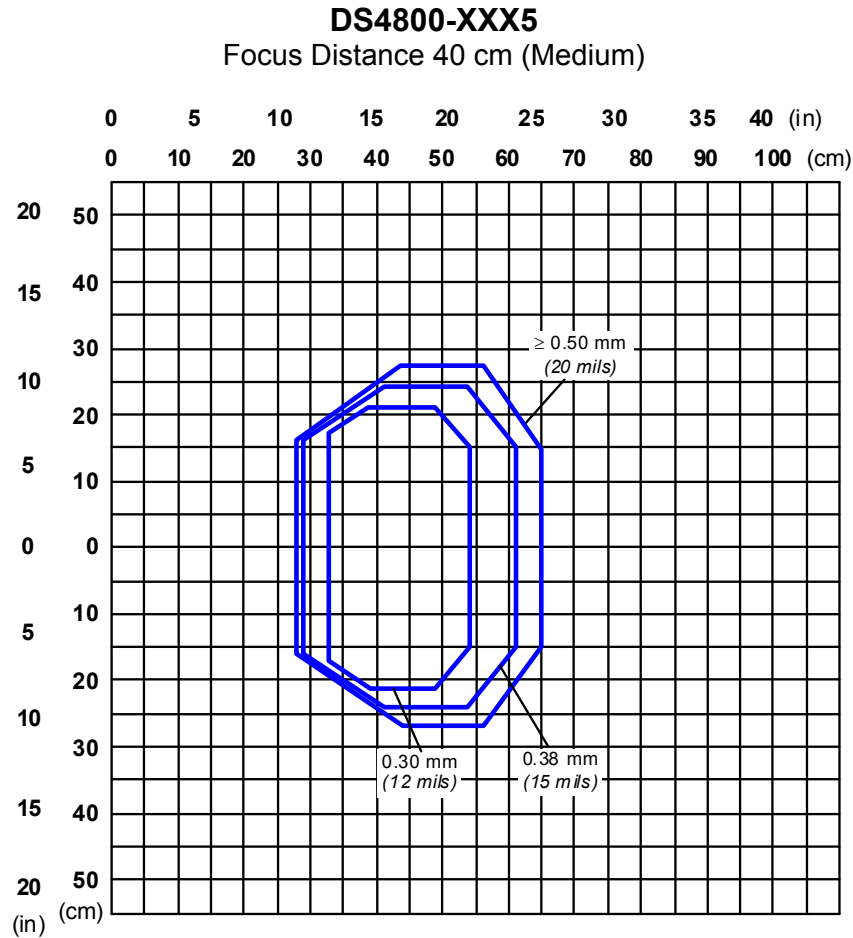

NOTE: (0,0) is the center of the laser beam output window.

CONDITIONS

Code	=	Code 128
PCS	=	0.90
"Pitch" angle	=	0°
"Skew" angle	=	15°
"Tilt" angle	=	0° to 30°
*Scan Speed	=	800 scans/sec.
*Reading Condition	=	Standard
* Reading Mode	=	Linear

* Parameter selectable in Genius™

For Tilt angles of 45°, the reading performance is reduced by approximately the following values:

Minimum reading distance: +20%
 Maximum reading distance: -25%
 Maximum reading width: -15%

DS4800-XXX5
Focus Distance 60 cm (Far)

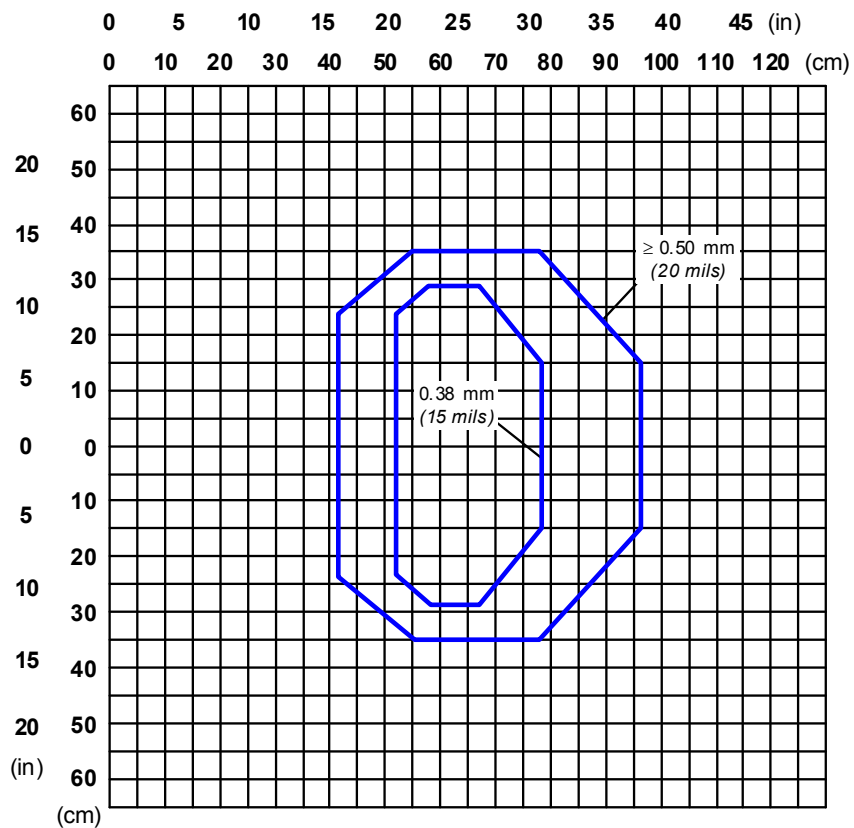

NOTE: (0,0) is the center of the laser beam output window.

CONDITIONS

- Code = Code 128
- PCS = 0.90
- "Pitch" angle = 0°
- "Skew" angle = 15°
- "Tilt" angle = 0° to 30°
- *Scan Speed = 800 scans/sec.
- *Reading Condition = Standard
- * Reading Mode = Linear

* Parameter selectable in Genius™

For Tilt angles of 45°, the reading performance is reduced by approximately the following values:

- Minimum reading distance: +20%
- Maximum reading distance: -15%
- Maximum reading width: -15%

8 MAINTENANCE

8.1 CLEANING

Clean the laser beam output window periodically for continued correct operation of the reader.

Dust, dirt, etc. on the window may alter the reading performance.

Repeat the operation frequently in particularly dirty environments.

Use soft material and alcohol to clean the window and avoid any abrasive substances.

**WARNING**

Clean the window of the DS4800 when the scanner is turned off or, at least, when the laser beam is deactivated.

9 TROUBLESHOOTING

9.1 GENERAL GUIDELINES

When wiring the device, pay careful attention to the signal name (acronym) on the CBX100/500 spring clamp connectors (chp. 4). If you are connecting directly to the scanner 25-pin connector pay attention to the pin number of the signals (chp 5).

If you need information about a certain reader parameter you can refer to the Genius™ program help files.

Either connect the device and select the parameter you're interested in by pressing the F1 key, or select **Help/Parameters Help/2K_4K Software Configuration Parameters Guide** from the command menu.

If you're unable to fix the problem and you're going to contact your local Datalogic office or Datalogic Partner or ARC, we suggest providing (if possible) the Device Configuration files (*.ddc). Connect through Genius™ and click the Save icon from the toolbar. Also note the exact Model, Serial Number and Order Number of the device.

TROUBLESHOOTING GUIDE	
Problem	Suggestions
Power On: the "Power On"/"Ready" LED is not lit	Is power connected? If using a power adapter (like PG 6000), is it connected to a wall outlet? If using rail power, does rail have power? If using CBX100, does it have power (check switch and LED)? Measure voltage either at pin 13 and pin 25 (for 25-pin connector) or at spring clamp Vdc and GND (for CBX).
On line Mode: TRIGGER LED is not lit (when external trigger activates)	Is sensor connected to I1A, I1B spring clamps (for CBX) or to pins 18 and 19 (for 25-pin connector)? Is power supplied to photo sensor? Are the photo sensor LEDS (if any) working correctly? Is the sensor/reflector system aligned?
On line Mode: TRIGGER LED is correctly lit but nothing happens (no reading results)	Is the software configuration consistent with the application condition (operating mode etc.)? In the Genius™ program select the Operating Mode branch and check for related parameters.
Serial On line Mode: the reader is not triggered (no reading results)	In the Genius™ program select the Operating Mode branch and check if Serial On Line is selected in the On Line Options. Are the Start – Stop characters correctly assigned? Is the serial trigger source correctly connected and configured?
On line Mode and Serial On Line: Reader doesn't respond correctly to the expected external signals end	In the Genius™ program select the Operating Mode branch and check the Reading Phase Timeout parameterization.
X-PRESS™: X-PRESS™ functions don't work. The multifunction keypress has no effect.	Check if the multifunction key is Locked through the Key Functionality parameter. Check if the multifunction key is Partially Locked through the Key Functionality parameter. Only the X-PRESS™ Autolearn function will be enabled and will only read the Lock/Unlock programming barcode. A message indicating this state is shown on the DS4800 Display.
X-PRESS™: X-PRESS™ functions don't work. LEDs light up but do not allow access to the functions.	Except for the Focus Lock/Unlock function, the X-PRESS™ functions don't work if the scanner motor or laser are turned off. Check if the motor or laser are turned off through the following parameters: <ul style="list-style-type: none"> • Beam Shutter = enabled • Scan Speed = Motor Off • Energy Saving>Serial Motor Off has been sent A message indicating one of these states is shown on the DS4800 Display.

TROUBLESHOOTING GUIDE	
Problem	Suggestions
<p>Reading: Not possible to read the target barcode (always returns No Read) or the Auto Setup procedure Fails.</p>	<p>Check synchronization of reading pulse with object to read: Is the scan line correctly positioned? Place barcode in the center of scan line and run Test mode (selectable by Genius™ as an Operating Mode). If you still have trouble, check the following:</p> <ul style="list-style-type: none"> • Is the reading distance within that allowed (see reading diagrams)? • Is the scanner correctly focused? • Is the Tilt angle too large? • Is the Skew angle less than 15° (direct reflection)? • Choose the Code Definition branch and enable different Code Symbologies (except Pharmacode). Length = Min and Max (variable). • Is the Bar Code quality sufficient? <p>If you had no success, try to perform the test using the BARCODE TEST CHART included with the product.</p>
<p>Communication: Device is not transmitting anything to the host</p>	<ul style="list-style-type: none"> • Is the serial cable connected? • Is the correct wiring respected? • Are serial host settings equivalent to the serial device setting? • If using CBX, be sure the RS485 termination switch is positioned to OFF.
<p>Communication: Data transferred to the host are incorrect, corrupted or incomplete</p>	<ul style="list-style-type: none"> • In the Genius™ program select the Data Communication Settings/Data Format/Standard Parameters branch and check the Header, Separators, and Terminator values • Also check the Code Field Length and Fill Character values. • Are the COM port parameters correctly assigned?
<p>Communication: Always returns the Reader Failure Character (<BEL> char as default)</p>	<ul style="list-style-type: none"> • Contact your local Datalogic office or Datalogic Partner or ARC, because either a Motor or Laser failure has occurred. • Note the exact model and Serial Number of the device.
<p>How do I obtain my units' serial numbers?</p>	<ul style="list-style-type: none"> • The device's serial number is printed on a label that is affixed to the body of the reader. • Serial numbers consist of 9 characters: one letter, 2 numbers, and another letter followed by 5 numbers.

10 TECHNICAL FEATURES

ELECTRICAL FEATURES		
Input Power		
Supply Voltage	10 - 30 Vdc; (24 Vdc \pm 10% for Subzero models)	
Maximum Consumption		
X0XX (Standard)	0.6 - 0.2 A; 6 W	
X1XX (OM)	0.75 - 0.25 A; 7.5 W	
XXX5 (Subzero)	1.2 A; 28.8 W @ 24 Vdc	
Serial Interfaces		
Main Serial Interface	SW programmable: RS232; RS485 FD and HD	
Baudrate	1200 - 115200	
Auxiliary	RS232	
Baudrate	1200 - 115200	
ID-NET™	RS485 Half-Duplex	
Baudrate	Up to 1 MBaud	
Inputs		
Input 1 (External Trigger), Input 2	Optocoupled, polarity insensitive	
Voltage	10 to 30 Vdc	
Current Consumption	12 mA max.	
Minimum Pulse Duration	5 ms.	
Outputs		
Output 1, Output 2	Optocoupled	
V _{CE}	30 Vdc max.	
Collector Current	40 mA continuous max.; 130 mA pulsed max.	
V _{CE saturation}	1V max. at 10 mA	
Power Dissipation	80 mW max. at 45 °C (ambient temperature)	
OPTICAL FEATURES		
Light Source	Semiconductor laser diode	
Wave Length	In the range 630 to 680 nm	
Safety Class	Class 2 - EN 60825-1; CDRH	
READING FEATURES (Note 1)		
Scan Rate (software programmable)	600 to 900 scans/sec	
Aperture Angle	50°	
Oscillating Amplitude (OM models)	40° \pm 2° (-5° to 35°)	
Oscillating Frequency (OM models)	0.2 to 20 Hz; 5 Hz max @ 40°; 20 Hz max @ 10°	
Maximum Reading Distance	See reading diagrams	
Maximum Resolution	See reading diagrams	
ENVIRONMENTAL FEATURES		
	STD and OM	Subzero
Operating Temperature (Note 2)	0° to +50 °C (+32° to +122 °F)	-35° to +50 °C (-31° to +122 °F) (Note 3)
Storage Temperature	-20° to +70 °C (-4° to +158 °F)	-35° to +70 °C (-31° to +158 °F)
Humidity max.	90% non condensing	
Vibration Resistance	14 mm @ 2 to 10 Hz; 1.5 mm @ 13 to 55 Hz;	
EN 60068-2-6	2 g @ 70 to 200 Hz; 2 hours on each axis	
Shock Resistance	30g; 11 ms;	
EN 60068-2-27	3 shocks on each axis	
Protection Class – EN 60529	IP65	
Ambient Light Rejection	30,000 LUX	
PHYSICAL FEATURES		
	STD and Subzero	OM
Mechanical Dimensions	85 x 101 x 42 mm (3.3 x 4 x 1.7 in)	123 x 117 x 48 mm (4.8 x 4.6 x 1.9 in)
Weight	580 g (20.5 oz.)	780 g (27.5 oz)

Note 1: Further details given in par. 7.3.

Note 2: If the reader is used in high temperature environments (over 40 °C), use of the Beam Shutter is advised (see the Genius™ configuration program) and/or a thermally conductive support (such as the metal bracket provided).

Note 3: The Operating Temperature is guaranteed under the following conditions: no direct ventilation on the scanner, fixed working environment (no rapid temperature changes). At -35 °C, a 20 min warm-up period is required before the scanner is ready to read barcodes.

SOFTWARE FEATURES	
READABLE CODES	
*EAN/UPC (including Add-on 2 and Add-on 5)	*Code 93
*2/5 Interleaved	*Code 128
*Code 39 (Standard and Full ASCII)	*EAN 128
*Codabar	ISBT 128
ABC Codabar	Pharmacode
*GS1 DataBar	Plessey
*GS1 DataBar Expanded	GS1 DataBar Limited
* ACR4™ Readable.	
Code Selection	up to ten different symbologies during one reading phase
Decoding Safety	can enable multiple good reads of same code
Headers and Terminators	Up to 128-byte header string Up to 128-byte terminator string
Operating Modes	On-Line, Serial On-Line, Verifier, Automatic, Continuous, Test
Configuration Methods	X-PRESS™ Functions Genius™ utility program Genius™ based Host Mode Programming
Special Functions	Code Verifier ACR4™ (Advanced Code Reconstruction) Motor Off and SW_Speed Control Programmable Diagnostic and Statistic Messages
Parameter Storage	Non-volatile internal Flash
USER INTERFACE	
LED Indicators	Ready, Good, Trigger, Com, Status, Power On
Multi-function Key	X-PRESS™ button
Display	2 lines x 16 characters menu and diagnostic messages configurable in multi-language

GLOSSARY

ACR4™ (Advanced Code Reconstruction)

This is a powerful code reconstruction technology (ACR™ 4). The new fourth generation ACR™ considerably increases the code reconstruction reading capability in the case of damaged or very tilted barcodes.

Aperture

Term used on the required CDRH warning labels to describe the laser exit window.

Barcode

A pattern of variable-width bars and spaces which represents numeric or alphanumeric data in machine-readable form. The general format of a barcode symbol consists of a leading margin, start character, data or message character, check character (if any), stop character, and trailing margin. Within this framework, each recognizable symbology uses its own unique format.

Barcode Label

A label that carries a barcode and can be affixed to an article.

Baud Rate

A unit used to measure communications speed or data transfer rate.

CDRH (Center for Devices and Radiological Health)

This organization (a service of the Food and Drug Administration) is responsible for the safety regulations governing acceptable limitations on electronic radiation from laser devices. Datalogic devices are in compliance with the CDRH regulations.

Code Positioning

Variation in code placement that affects the ability of a scanner to read a code. The terms Pitch, Skew, and Tilt deal with the angular variations of code positioning in the X, Y and Z axes. See pars. 3.2.1 and 3.3. Variations in code placement affect the pulse width and therefore the decoding of the code. Pulse width is defined as a change from the leading edge of a bar or space to the trailing edge of a bar or space over time. Pulse width is also referred to as a transition. Tilt, pitch, and skew impact the pulse width of the code.

Decode

The process of translating a barcode into data characters using a specific set of rules for each symbology.

Decoder

As part of a barcode reading system, the electronic package which receives the signals from the scanner, performs the algorithm to interpret the signals into meaningful data and provides the interface to other devices. The decoder is normally integrated into the scanner.

EAN

European Article Number System. The international standard barcode for retail food packages.

FLASH

An on-board non-volatile memory chip.

Full Duplex

Simultaneous, two-way, independent transmission in both directions.

Half Duplex

Transmission in either direction, but not simultaneously.

Host

A computer that serves other terminals in a network, providing services such as network control, database access, special programs, supervisory programs, or programming languages.

Interface

A shared boundary defined by common physical interconnection characteristics, signal characteristics and meanings of interchanged signals.

LED (Light Emitting Diode)

A low power electronic device that can serve as a visible or near infrared light source when voltage is applied continuously or in pulses. It is commonly used as an indicator light and uses less power than an incandescent light bulb but more than a Liquid Crystal Display (LCD). LEDs have extremely long lifetimes when properly operated.

Multidrop Line

A single communications circuit that interconnects many stations, each of which contains terminal devices. See RS485.

Parameter

A value that you specify to a program. Typically parameters are set to configure a device to have particular operating characteristics.

Picket-Fence Orientation

When the barcode's bars are positioned vertically on the product, causing them to appear as a picket fence. The first bar will enter the scan window first. See par. 7.2.2.

Pitch

Rotation of a code pattern about the X-axis. The normal distance between center line or adjacent characters. See pars. 3.2.1 and 3.3.

Position

The position of a scanner or light source in relation to the target of a receiving element.

Protocol

A formal set of conventions governing the formatting and relative timing of message exchange between two communicating systems.

Raster

The process of projecting the laser beam at varied angles spaced evenly from each other. Typically, the mirrored rotor surfaces are angled to create multiple scan lines instead of a single beam.

Resolution

The narrowest element dimension, which can be distinguished by a particular reading device or printed with a particular device or method.

RS232

Interface between data terminal equipment and data communication equipment employing serial binary data interchange.

RS485

Interface that specifies the electrical characteristics of generators and receivers for use in balanced digital multipoint systems such as on a Multidrop line.

Scanner

A device that examines a printed pattern (barcode) and either passes the uninterpreted data to a decoder or decodes the data and passes it onto the Host system.

Serial Port

An I/O port used to connect a scanner to your computer, identifiable by a 9-pin or 25-pin connector.

Signal

An impulse or fluctuating electrical quantity (i.e.: a voltage or current) the variations of which represent changes in information.

Skew

Rotation about the Y-axis. Rotational deviation from correct horizontal and vertical orientation; may apply to single character, line or entire encoded item. See pars. 3.2.1 and 3.3.

Step-Ladder Orientation

When the barcode's bars are positioned horizontally on the product, causing them to appear as a ladder. The ends of all bars will enter the scan window first. See par. 7.2.1.

Symbol

A combination of characters including start/stop and checksum characters, as required, that form a complete scannable barcode.

Tilt

Rotation around the Z axis. Used to describe the position of the barcode with respect to the laser scan line. See pars. 3.2.1 and 3.3.

Trigger Signal

A signal, typically provided by a photoelectric sensor or proximity switch, which informs the scanner of the presence of an object within its reading zone.

UPC

Acronym for Universal Product Code. The standard barcode type for retail food packaging in the United States.

Visible Laser Diode

A light source used in scanners to illuminate the barcode symbol. Generates visible red light at wavelengths between 630 and 680 nm.

INDEX

2

25-Pin Cable Electrical Connections, 60

A

Accessories, 31

ACR™ 4, 88

Auxiliary RS232 Interface, 53, 71

C

CBX Electrical Connections, 42

CE Compliance, vii

Cleaning, 104

Code Verifier, 57, 75

D

Display, 25

Display Messages, 26

DS4800 Description, 18

F

FCC Compliance, vii

G

General View, x

Glossary, 110

H

Handling, viii

I

ID-NET™, 81

ID-NET™ Cables, 48, 66

ID-NET™ Interface, 48, 66

ID-NET™ Network Termination, 53, 71

ID-NET™ Response Time, 49, 67

Inputs, 54, 72

Installation, 33

L

Laser Safety, vi

LEDs, 19

Linear Code Reading, 92

M

Main Serial Interface, 43, 61

Mechanical Installation, 34

Model Description, 31

Mounting DS4800, 37

Multiplexer Layout, 87

O

Oscillating Mirror Models, 29

Outputs, 57, 75

P

Package Contents, 33

Pass-Through, 79

Patents, v

Performance, 94

Picket-Fence Mode, 93

Point-to-Point, 77

Positioning, 40

Power Supply, vii, 43, 61

R

Reading Diagrams, 95

Reading Features, 88

References, v

RS232 Interface, 44, 62

RS232 Master/Slave, 86

RS485 Full Duplex, 45, 63

RS485 Half Duplex, 46, 64

S

Services and Support, v

Step-Ladder Mode, 92

T

Technical Features, 108

Troubleshooting, 105

Typical Layouts, 77

X

X-PRESS™ Human Machine Interface, 22

**Datalogic Automation S.r.l.**

Via S. Vitalino 13
40012 Lippo di Calderara di Reno
Bologna – Italy
www.automation.datalogic.com

declares that the

DS4800; Laser Scanner

and all its models

are in conformity with the requirements of the European Council Directives listed below:

2004 / 108 / EC EMC Directive

This Declaration is based upon compliance of the products to the following standards:

EN 55022 (CLASS A ITE), SEPTEMBER 1998:

*INFORMATION TECHNOLOGY EQUIPMENT
RADIO DISTURBANCE CHARACTERISTICS
LIMITS AND METHODS OF MEASUREMENTS*

EN 61000-6-2, SEPTEMBER 2005:

*ELECTROMAGNETIC COMPATIBILITY (EMC)
PART 6-2: GENERIC STANDARDS - IMMUNITY FOR INDUSTRIAL
ENVIRONMENTS*

Lippo di Calderara, July 16th, 2009

Lorenzo Girotti
Product & Process Quality Manager

